

PINNACLE SERIES PACEMAKERS

PRO MRI

TECHNICAL / PHYSICIAN / USER

MANUAL

Version 1.1

- **PINNACLE Pacemaker SSI**
Single Chamber Multi programmable Pacemaker (SSI)
Model Number: 8820 PRO MRI
- **PINNACLE R Pacemaker (SSI / SSIR)**
Single Chamber Rate Responsive Pacemaker
Model Number: 297 PRO MRI



Shree Pacetronix Ltd.

Plot no. 15, sector II,
Pithampur, Dist.: Dhar
454775, Madhya Pradesh



Shree Pacetronix Ltd.

Revision History

Revision	Date	Change Description
03	July 04, 2015	New EC Rep
04	July 15, 2016	User Information
05	June 10, 2017	Added Parameters
06	August 26, 2017	MRI Information
07	July 01, 2020	EC & Specification

Contents

1	DEVICE DESCRIPTION	7
	<i>Manual Description</i>	7
	Technical Manual	8
	<i>Device Overview</i>	9
	<i>Indication For Use</i>	10
	<i>Contraindication</i>	10
2	SPECIFICATIONS	11
	<i>Physical Characteristics</i>	11
	<i>Parameter Values</i>	12
	<i>Added Parameters</i>	14
	<i>Features & Diagnostics Parameters</i>	15
	<i>Battery Chemistry & Longitivity</i>	16
	<i>Shipping, Nominal / Reset and Emergency Parameters</i>	17
3	FEATURES.....	18
	<i>Testing the Pacemaker</i>	18
	<i>Tachycardia Treatment</i>	18
	<i>Magnet Response</i>	18
	<i>Noise Detection</i>	18
	<i>Temporary Programming</i>	18
	<i>MRI Test</i>	18
	• <i>Care in MRI Test</i>	19
	<i>Parameters at MRI test</i>	20
4	PACKAGE INFORMATION	21
	<i>Contents of Sterile Package</i>	21
	<i>Handling & Storage</i>	21
	<i>Sterilization</i>	21
	<i>Shelf Life</i>	21
5	POWER SOURCE AND CURRENT CONSUMPTION	22
	<i>Current Consumption</i>	22
	<i>Longitivity</i>	22
	<i>Battery Capacity Indicator</i>	22
6	PARAMETERS	23
	<i>Operating Modes</i>	23
	Non Rate Responsive Modes	23
	Rate Responsive Modes	24
	<i>Rates</i>	25

	Basic Rate.....	25
	Hysteresis	25
	<i>Sensing</i>	25
	Sensitivity.....	27
	Sensing Polarity.....	27
	<i>Pacing</i>	27
	Pulse Shape	27
	Pulse Width	28
	Pulse Amplitude	28
	Pacing Polarity	28
	<i>Rate Responsive Parameters</i>	28
	Basic Rate.....	28
	Upper Rate.....	28
	Slope.....	28
	Reaction Time	28
	Recovery Time	29
	Automatic Refractory Change.....	29
	<i>Diagnostic Features</i>	29
	Impedance	29
	Interference Detection	29
	Marker Mode.....	29
	Statistics	29
	Threshold Measurement	29
	<i>Added Parameters</i>	30
	Night Rate	30
	Rate Drop	30
	Lead Monitoring.....	32
	Implant Data & Patient Info.....	32
	Set Date & Time.....	32
7	PROGRAMMING SYSTEM	34
	<i>Programming Package</i>	34
	<i>Connections of Programming System</i>	35
	<i>Interrogate the Device</i>	36
	<i>Program the Device</i>	36
	Physician Manual	37
8	IMPLANT PROCEDURE	38
	<i>Opening a Sterile Package</i>	38

	<i>Verify lead and connector compatibility</i>	38
	<i>Lead Implantation</i>	39
	<i>Test the lead system</i>	40
	<i>Connect the lead to the device</i>	41
	<i>Test the device operation</i>	43
	<i>Position and secure the device</i>	43
	<i>Program the device</i>	44
	<i>Replace a device</i>	44
9	EXPLANT PROCEDURE	45
	<i>Pacemaker battery replacement:</i>	45
10	FOLLOW UP CARE	47
	<i>Follow-up information</i>	47
	<i>Reviewing information saved by your pacemaker</i>	47
	<i>When to call your doctor</i>	48
	<i>Caring for yourself</i>	48
	<i>Dealing with anxiety and getting the support you need</i>	48
	<i>Medical care</i>	49
	<i>Planning for an emergency</i>	49
	<i>User Manual</i>	50
11	THE HEALTHY HEART	51
	<i>Arrhythmias</i>	54
12	SOME BASIC FACTS ABOUT PG	56
13	RISK & BENEFITS	58
14	SURGERY FOR THE PULSE GENERATOR	59
15	COMING HOME AFTER SURGERY	61
	<i>Right after the operation</i>	61
16	LIVING WITH YOUR PULSE GENERATOR	62
17	WARNINGS	66
	<i>Device operation</i>	66
	<i>Pacemaker-dependent patients</i>	66
	<i>Sensitivities at which Interference may be expected</i>	66
	<i>Cremation and Incineration</i>	66
	<i>Reuse</i>	67
	<i>Myopotential</i>	67
	<i>Muscle Stimulation in unipolar configurations</i>	67
	<i>Random Failures</i>	67
	<i>Environmental Hazards</i>	67
18	PRECAUTIONS	68

	<i>Handling and storage instructions</i>	68
19	ELECTROMAGNETIC INTERFERENCE	69
20	POTEINTIAL ADVERSE EFFECTS	75
21	SIDE EFFECTS	75
22	SYMBOLS	76
	<i>Explanation of Symbols</i>	76
23	TABLES	78
24	FIGURES	78
25	Warranty	79
26	TECHNICAL SERVICE	80
27	GLOSSARY	80

1 DEVICE DESCRIPTION

Manual Description This document is a Technical, Physician & User manual. This contains the specification, implant information, programmer details, warning, precaution etc. of the **Pinnacle series pacemaker**

Pacemaker Name	Pacemaker Model	Type
Pinnacle	8820 PRO MRI	SSI
Pinnacle R	297 PRO MRI	SSI/SSIR

Besides all the information concerning programmable parameters, data regarding the device's identification, battery voltage, lead impedance and statistic counters can be obtained.

Log storage of follow-up such as battery measurements, threshold measurement are described in the product documentation that is included with the software that supports this device. To obtain additional copies of product documentation, contact a Pacetronix representative.

This manual describes the Pinnacle series Implantable pulse generators (IPGs) as:

- Pinnacle Model **8820 PRO MRI**, (SSI) multi programmable Pulse generator.
- Pinnacle R Model **297 PRO MRI**, (SSI / SSIR) multi programmable rate responsive Pulse generator

Rate response Rate response is controlled through an activity-based sensor

Programmer and software Use the appropriate **Pacetronix** programmer and software to program above device. Programmers from other manufacturers are not compatible with Pacetronix devices.

Contents of sterile package The package contains one implantable pulse generator and one torque wrench (Screw driver)

Technical Manual

Device Overview The Pinnacle series system consists of the following devices:

- Pinnacle Model 8820 PRO MRI (SSI Pacemaker)
- Pinnacle R Model 297 PRO MRI (SSIR pacemaker)
- Lead & Programming System

NOTE: Both Pinnacle Model 8820 PRO MRI & Pinnacle R Model 297 PRO MRI will be referred as “**Pinnacle series Devices**” in whole document.

Pinnacle series devices are implantable, single-chamber, multi-programmable telemetric pulse generators, manufactured by Shree Pacetronix Ltd. The Pinnacle series devices are unicameral cardiac pacemakers. They are anti-bradycardia devices intended to improve cardiac output.

The Pinnacle series devices are multi-programmable, i.e., the value of the parameters that rule their functioning can be set by the attending medical personnel according to the patient's needs.

The Pinnacle series devices send diagnostic data to a Programming System, which can be used to interact with the device. The programming system has facilities for modifying the parameters of the device, recording statistics, maintaining a log of the activity of the device, printing reports, recording standard programs for future use, reprogramming the device with safe values in emergency situations etc.

The Pinnacle series devices are connected to one lead, which can be positioned either in the Atrium or in the Ventricle. They accept standard pacemaker leads with IS-1- BI/UNI connectors.

Pinnacle R Model 297 PRO MRI devices have rate response facilities. Parameters that control the functioning of the Pinnacle series implantable devices can be programmed using telemetry, in the ranges.

Besides all the information concerning programmable parameters, data regarding the device's identification, battery voltage, lead impedance and statistic counters can be obtained.

Warning: Bipolar / Unipolar (Model 3744VB PROMRI & 3851VB PROMRI) leads may be used with the Pinnacle Series PROMRI pacemaker but if other than MRI safe lead is used (e.g. 3851VB / 3844VB), the system is contraindicated for MRI scans.

The MRI safe feature permits a mode of operation that allows a

patient with a MRI safe device to be safely scanned by an MRI machine while the device continues to provide appropriate pacing. When programmed to on, MRI safe operation disables arrhythmia detection, magnet mode, and all user-defined diagnostics. **Before performing an MRI, refer MRI specific warnings and precautions.**

Indication For Use

Pinnacle series pulse generators are unicameral anti-bradycardia implantable devices intended for permanent Ventricular or Atrial pacing applications. Their use may be indicated in the treatment of patients with deficient cardiac impulse generation systems or with deficient conduction.

The Pinnacle R Model 297 PRO MRI implantable rate responsive pulse generators are indicated for use in patients who may benefit from rate responsive pacing to support cardiac output during varying levels of activity. These devices are indicated for use in patients who have experienced one or more of the following conditions:

- Symptomatic paroxysmal or permanent second or third degree AV block
- Symptomatic bilateral bundle branch block.
- Transient sinus node dysfunctions with or without associated AV conduction disorders.
- Bradycardia-tachycardia syndrome.

Contraindication

There are no general contraindications to the use of ventricular pacing as a means of controlling heart rate. However, the patient's age and medical condition may dictate the particular pacing system and mode of operation used by the physician.

Pinnacle series devices are contraindicated for atrial pacing in the presence of an A-V conduction disturbance.

Rate responsive pacing (for Pinnacle R Model 297 PRO MRI devices) is not appropriate for the patients who cannot tolerate increments in the pacing rate.

Pinnacle Series implantable pulse generators (IPGs) are contraindicated for asynchronous pacing in the presence (or likelihood) of competition between paced and intrinsic rhythms

2

SPECIFICATIONS

*Physical
Characteristics***Table 01: Physical Characteristics**

Description	Pinnacle Model 8820 PROMRI	Pinnacle R Model 297 PRO MRI
Length	49 mm	49 mm
Height	38 mm	38 mm
Thickness	8 mm	8 mm
Mass	25 gms.	25 gms.
Volume	12 CC.	12 CC.
Connector Type	IS-1 BI	IS-1 BI
Material in contact with human tissue ^{*1}	<ul style="list-style-type: none"> • Titanium • Epoxy Resin • Silicon Rubber 	<ul style="list-style-type: none"> • Titanium • Epoxy Resin • Silicon Rubber

(*1) These materials have been successfully tested to be biocompatible. Pinnacle series devices do not cause temperature increase that can cause injury to the surrounding tissues.

*Parameter Values***Table 02: Pacemaker Parameters**

Parameters	Values (Pinnacle Model 8820 PRO MRI)	Values (Pinnacle R Model 297 PRO MRI)
GENERAL PARAMETERS		
Pacing Modes	VVI, VVT, VOO, AAI, AAT, AOO, OAO, OVO, OFF	VVI, VVT, VOO, AAI, AAT, AOO, OAO, OVO VVIR, VOOR, VVTR, AAIR, AOOR, AATR, OFF
Basic Pacing Rates	From 32 BPM to 120 BPM.	From 30 BPM to 120 BPM.
Upper Rate	From 80 BPM to 180 BPM in steps of 2 BPM. (In SST Mode)	From 80 BPM to 180 BPM in steps of 2 BPM. (In SST Mode)
Upper Sensor Rate	NA	From 80 BPM to 180 BPM in steps of 2 BPM.
PACING, SENSING & HYSTERESIS PARAMETERS		
Amplitude	From 0.2 V to 7.5 V	From 0.2 V to 7.5 V
Pulse Width	0.07 ms and from 0.1 ms to 1.5 ms in steps of 0.1 ms	0.07 ms and from 0.1 ms to 1.5 ms in steps of 0.1 ms

Pacing Polarity	Unipolar /Bipolar	Unipolar /Bipolar
SENSING PARAMETERS		
Sensitivity	From 0.5 mV to 7.5 mV	From 0.5 mV to 7.5 mV
Sensing Polarity	Unipolar / Bipolar	Unipolar / Bipolar
Refractory Period	From 200 ms to 500 ms in steps of 15 ms	From 200 ms to 500 ms in steps of 15 ms
HYSTERISIS PARAMETERS		
Hysteresis Enable	On / Off	On / Off
Hysteresis Rate Change	From 2 BPM to 40 BPM in steps of 2 BPM	From 2 BPM to 40 BPM in steps of 2 BPM
Hysteresis Search	On / Off	On / Off
Blanking Period	100ms	100ms

Added Parameters

Table 02A: Other Parameters

Parameters	Values (Pinnacle Model 8820 PRO MRI)	Values (Pinnacle R Model 297 PRO MRI)
OTHERS PARAMETRS		
Implant Data (Form)	Yes	Yes
Patient Info (Follow Up form)	Yes (Save as PDF or JPG)	Yes (Save as PDF or JPG)
Pacemaker Date & Time	Yes	Yes
ECG/Marker Window	ECG Window can be enlarged for better visibility of ECG waveform.	ECG Window can be enlarged for better visibility of ECG waveform.

Features & Diagnostics Parameters**Table 03 : Features & Diagnostics Parameters**

Rate Responsive Parameters (Activity) Parameters (For Pinnacle R Model 297 PRO MRI)	
Upper Activity Rate	From 80 BPM to 180 BPM in steps of 2 BPM
Activity Rate Response (Slope)	From 1 to 16, in steps of 1.
Reaction Time (Up Time)	From 10 s to 60 s in steps of 10 s
Recovery Time (Down Time)	From 1 m to 10 m in steps of 1 m
Automatic Refractory Change	On/Off. When programmed On, if the rate is greater than 120 BPM, the refractory switch to the minimum value between the programmed value and 250 ms.
Activity Level Measurement	Yes
Features	
Rate Hysteresis	Yes
Magnet Response	Yes
Noise Detection	Yes
High Rate Temporary programming	Yes
Auto Measure (Auto threshold Measurement)	ON / OFF
Diagnostic Parameters	
Marker Mode	Pacing & Sensing markers
Statistics	Pace / Sense Counts, Rate histogram, Impedance values & graphs, Noise count & Noise pacing count,
Rate Histogram	Yes
MRI Safe Mode (MRI Safe with Pacetronix MRI Safe Lead)	Yes [PROMRI pacemaker is tested in 3T (Tesla) MRI system, with body scan].

Impedance Measurement	Lead Impedance
Threshold Measurement	Pacing threshold, Sensing Threshold
Temporary Programming rates	From 32 BPM to 380 BPM
Device Longevity	Pacemakers Battery Life calculation (Based on mathematical calculations)
ECG	Surface ECG (3 Electrodes ECG) & recording
LOG	Log of Marker events, ECG, Threshold test, Patient de tails & all other activities (Programming parameters, Magnet, Impedance, Noise etc..)
Magnetic Response	BOL: SOO mode. Rate 96 BPM. ERI: SOO mode. Rate 84 BPM. EOL: SOO mode. Rate 64 BPM

Battery Chemistry & Longevity

Table 04: Battery & Pacemaker Life

Battery Chemistry	Lithium Iodine
Battery Initial Voltage	2.8 Volts
Battery level Indication	BOL , ERI & EOL (Software displays these indications along with Battery value)
Service life	The expected life of the Pacemaker, pacing 100% at 60 PPM, SSI mode, with 2.5 V amplitude, pulse width of 0.4 ms and lead impedance 500 Ohms, is more than 8 Years

Shipping, Nominal / Reset and Emergency Parameters**Table 05: Shipping, Nominal & Emergency Parameters**

Parameters	Shipping	Nominal / Reset	Emergency
Pacing Modes	VVI	VVI	VVI
Basic Pacing Rates	60 BPM	60 BPM	60 BPM
Amplitude	2.5 V	5.0 V	5.0 V
Pulse Width	0.4 ms	0.5 ms	0.5 ms
Pacing Polarity	Bipolar	Unipolar	Unipolar
Sensitivity	2.5 mV	1.5 mV	1.5 mV
Sensing Polarity	Bipolar	Unipolar	Unipolar
Refractory Period	320 ms	320 ms	320 ms
Hysteresis	Off	Off	Off
Auto Measure	Off	Off	Off

3 FEATURES

Testing the Pacemaker In order to test if the pacing output is enough to stimulate the heart, switch the working mode to an asynchronous one (using a magnet or the SPL programmer). Once the pacemaker mode has been changed, the stimuli can be detected using an electrocardiograph.

Tachycardia Treatment Pinnacle series pacemakers have features for tachycardia treatment: temporary programming (refer “temporary programming”) consists in switching the pacemaker to an asynchronous mode at a special programmed rate. Usually a much higher rate than the basic pacing rate. The asynchronous pacing is maintained until the programmer head is put away from the pacemaker. In this moment, the pacemaker goes back to the original working mode (set pacing rate). With the asynchronous stimulation at a high rate, the heart is stimulated in different moments of the cycle, helping to revert the tachycardia.

Note: - Temporary programming is available only in **Ventricle**.

Magnet Response After putting magnet over pacemaker, it will pace asynchronously. Following will be the response after putting magnet over pacemaker :-

- a) **BOL:** VOO/AOO mode. Rate 96 BPM.
- b) **ERI:** VOO/AOO mode. Rate 84 BPM.
- c) **EOL:** VOO/AOO mode. Rate 64 BPM

Noise Detection Input signal with frequency more than 10Hz will be considered as a noise & pacemaker will automatically switch to asynchronous mode

Temporary Programming **In Temporary Programming** mode the pacemaker paces with a high rate in Asynchronous mode. The temporary programming mode ends when the programming head is moved away from the chest / Pacemaker of the patient. It is used to suppress high rate episodes.

MRI Test A magnetic resonance imaging (MRI) is a type of imaging that uses magnetic fields to construct an inside view of the body, which helps doctors for diagnostic purposes. You can undergo an MRI scan if your pacing system consists of Pacetronix MRI safe pacemaker and MRI safe leads.

“MRI safe mode” feature can be enabled from pop down under “Tools” tabs. Turn ON MRI safe switch and program the pacemaker with following parameters or as suggested by physician:

- Mode : SOO
- Amplitude : 5 V
- Pulse width: 0.5 ms

Note: *Ensure both Pacemaker & Lead are MRI safe prior to MRI test.*

The electromagnetic fields of MRI scans have the potential to cause hazardous effects on pacemakers as well as lead, which can result in cardiac tissue heating, inappropriate pacing, and dangerous arrhythmias.

These risks are reduced to a very low level so that under specified conditions, patients may safely undergo MRI scans.

The MRI pacemaker and its leads should be used in the MRI environment. Any other pacing system combination may result in a hazard to the patient during an MRI scan. When MRI feature is ON, it allows the patient to go under MRI scan safely while the device pace continuously.

MRI scanning is prescribed by your physician. This is not a common treatment. Please consult with your doctor. Your doctor should discuss all potential benefits and risks with you.

- Care in MRI Test

Following should be taken care----

1. Patient should undergo MRI scanning at least after 2 months period of Implantation.
2. Before going for MRI pretesting of pacemaker is required and parameters should be noted.
3. There is no change in other Specifications of pacemaker and lead. Model no of lead is given as IS1 BI 3851VB PROMRI for bipolar passive lead and IS1 BI 3744VB PROMRI for screw-in lead.
4. Pacemaker should be programmed in MRI safe mode before undergoing MRI test.
5. It should be programmed with Pacetronix MRI compatible software.
6. The Lead impedance should be in the range of 400 to 900 ohms.
7. Pacing threshold should be less than 1.5 V.

Transmit and Receive coils should not be placed directly over the pacing system because this has not been evaluated and such use is contraindicated.

Patients having diaphragmatic stimulation at a pacing output of 5.0 V and pulse width of 1.0 ms are contraindicated for an MRI scan.

8. Before going for MRI the pacemaker should be programmed with MRI "ON" with below parameters.

Parameters at MRI test

Pacemaker parameters, to be programmed, are as below:

Mode	VOO
Amplitude	5.0V
Rate	70ppm or As suggested by Doctor
Pulse width	0.5 ms
MRI Safe	ON

1. The whole body averaged specific absorption rate (SAR) must be < 2.0 Watts per kilogram (**W/kg**).
2. The head SAR must be < 3.2 W/kg.
3. Pacemaker is tested in 3T (Tesla) Field. Please refer report. It's a bench testing to check MRI effect on pacemaker's functioning, heating effect and image artifacts.
4. During MRI test, ECG should be monitored and Defibrillator also should be kept ready.
5. After MRI the pacemaker should be tested for impedance and pacing threshold and these should be within range.
6. After testing pacemaker should be programmed back to normal parameters.
7. Kindly make a record, if any heating effect is sensed by the patient at pacemaker or electrode site.
8. Please note of any arrhythmia, discomfort to the patient.
9. Please send complete MRI report to Pacetronix with its images along with doctor's comments.

4

PACKAGE INFORMATION

**Contents of
Sterile Package**

- Implantable pulse generator.
- Torque wrench screw driver
- Documents
 - Pacemaker registration form
 - Pacemaker Identification card (ID Card)
 - Pacemaker Manual

**Handling &
Storage**

The pacemaker can be damaged if it falls down on a hard surface. Do not implant the pacemaker if the **package is damaged**. Damaged packages must be returned to the manufacturer.

The generator should not be stored for long periods in rooms where the temperature can exceed 52°C (125°F) or under 4°C

Storage temperature range: 4°C to 52°C.

Sterilization

The Pinnacle series pacemaker's sterilization is done with **Ethylene Oxide** gas.

Pinnacle series implantable devices are supplied by the manufacturer in a sterile state provided the container is intact. If the packaging is wet, punctured, opened, or otherwise damaged, return the device to the manufacturer. If the package has been opened and the pacemaker has not been used, it should be sterilized again with Ethylene oxide gas (only in Pacetronix).

The pacemaker should not be sterilized using an autoclave. It should neither be cleaned using ultrasound. In sterilization, the pacemaker should be packed in a permeable box with Ethylene oxide gas. The temperature of the process should not exceed 52°C (125°F). The necessary cautions should be taken in order to eliminate the Ethylene oxide vestiges before doing the implantation.

The efficacy of the sterilization process should be controlled through biological methods. Never attempt to resterilize a Pinnacle series device or the torque wrench.

A Pinnacle series device that has been explanted for any reason must not be re-used for implantation in another patient.

Shelf Life

Shelf life of sterilized device is 4 years from the date of sterilization.

5

POWER SOURCE AND CURRENT CONSUMPTION

- The PINNACLE series devices are powered by a Lithium-Iodine battery, Model LI 3150.
- The initial voltage of the battery is 2.8 V.
- The usable capacity of the battery is 1.28Ah.

Current Consumption The current consumption of a PINNACLE series device with a rate of 60 PPM, 2.5 V Amplitude and Pulse Width of 0.4 ms is:

- **For PINNACLE MODEL 8820 PRO MRI model in VVI/AAI mode:**
 - 11 amps with a 500 Ohm load, and
 - 9.0 amps when inhibited.
- **For PINNACLE R MODEL 297 PRO MRI model in VVIR/AAIR mode:**
 - 13 amps with a 500 Ohm load, and
 - 10 amps when inhibited.

Longevity The expected longevity for an PINNACLE series device, pacing 100% at 60 PPM, with 2.5 V Amplitude, Pulse Width of 0.4 ms and a 500 Ohm load is:

- For Pinnacle Model 8820 PRO MRI is 10 years, in VVI/AAI mode.
- For Pinnacle R Model 297 PRO MRI is 8.2 years in VVIR/AAIR mode.

Battery Capacity Indicator The attending physician can inspect the state of the battery of an implanted PINNACLE series device using an electro- cardiograph and a magnet. To do this, place a magnet over the implant site and parallel to the device. In the presence of a magnet, PINNACLE series devices change their mode to VOO/AOO. In this mode, the devices deliver pace stimulus in the programmed basic rate regardless of any intrinsic heart activity. The PINNACLE series devices respond to magnet influence with different pacing frequencies, according to the remaining capacity of their battery in the following way:

- **Beginning of Life (BOL):** At BOL i.e. battery voltage above 2.5 V, applying a magnet sets the pacing rate to 96 PPM.
- **Elective Replacement Indicator (ERI):** At ERI the battery

voltage reaches to 2.50 volts, on applying a magnet over pacemaker, the pacing rate sets to 84 PPM till the magnet is over the pacemaker.

- **End of Life (EOL):** At EOL, the battery voltage reaches to 2.30 volts, on applying a magnet over pacemaker, the pacing rate sets to 64 PPM till the magnet is over the pacemaker. For the Pinnacle R Model 297 PRO MRI devices, the Activity Sensor reports activity level '0'. This takes place automatically: no magnet application is needed. Besides, applying a magnet will cause the device mode switch to VOO/A00.

After the ERI condition is reported, the remaining lifetime of the device, programmed in VVI Mode, Rate 60 PPM, Amplitude 2.5 V and Pulse width 0.4 ms, is approx 6 months. Under the same conditions, after the EOL condition is reported, the remaining lifetime of the device is approx 1 to 2 months.

6

PARAMETERS

Operating Modes This chapter describes the operating modes of the PINNACLE series implantable devices.

The Operating Mode of the implanted PINNACLE series devices can be set through the Programmer (Refer Table 02 for all operating modes of both Pinnacle Model 8820 PRO MRI & Pinnacle R Model 297 PRO MRI).

Non Rate Responsive Modes

AAI / VVI Modes:

The implanted PINNACLE series device **delivers** pace stimulus at the programmed basic rate if no intrinsic heart event is detected before the programmed period end and outside the refractory period.

If a heart event is detected, pacing is **inhibited** and the device timing sequence is restarted.

AAT / VVT Modes:

The implanted PINNACLE series device **delivers** pace stimulus at the programmed basic rate if no intrinsic heart event is detected before the programmed period end and outside the refractory period.

If an intrinsic heart event is detected, it **triggers** the pace stimulus, i.e., a pace stimulus is immediately sent, and the device timing sequence is restarted.

In these modes, the **Upper Rate** parameter indicates the maximum intrinsic

rate for which pace stimulus will be delivered. That is, if the period between an intrinsic sensed event and the previous stimulus is smaller than the value of the period corresponding to this parameter, no pace signal will be delivered after the intrinsic heart event.

The Upper Rate parameter can be set through the Programmer between 80 and 180 PPM in 28 settings.

AOO / VOO Modes

The implanted PINNACLE series device delivers pace stimulus at the programmed basic rate regardless of any intrinsic heart activity.

OAO / OVO Modes

The implanted PINNACLE series device only detects intrinsic heart activity without pacing.

These modes are only for diagnosis purposes, and must be used with precaution.

Rate Responsive Modes

These modes are only available for Pinnacle R Model 297 PRO MRI device. These devices contain an activity sensor that can detect acceleration resulting from physical activity. When the device is set in a rate responsive operation mode, patient's physical activity determines an *activity level*, which is used jointly with the rate response parameters to determine the pacing rate in each cardiac interval.

The behavior of the implanted device in the rate responsive modes is equal to the one in the corresponding non rate responsive modes, except that the rate is not fixed but calculated for each cycle as a function of the programmed rate response parameters, the activity level and the former rate (See "Rate response parameter").

AAIR / VVIR Modes

The Pinnacle R Model 297 PRO MRI implanted device delivers pace stimulus at the rate determined by the activity sensor and the rate response parameters if no intrinsic heart event is detected before the corresponding period end and outside the refractory period.

If a heart event is detected, the pacing is *inhibited*, and the device timing sequence is restarted.

AATR / VVTR Modes

The Pinnacle R Model 297 PRO MRI implanted device *delivers* pace stimulus at the rate determined by the activity sensor and the rate response parameters if no intrinsic heart event is detected before the corresponding period end and outside the refractory period.

If an intrinsic heart event is detected, it *triggers* the pace stimulus, i.e., a pace stimulus is immediately sent, and the device timing sequence is restarted.

In these modes, the **Upper Rate** parameter indicates the maximum intrinsic rate for which pace stimulus will be delivered. That is, if the period between an intrinsic sensed event and the previous stimulus is smaller than the value of the period corresponding to this parameter, no pace signal will be delivered after the intrinsic heart event.

The Upper Rate parameter can be set through the Programmer between 80 and 180 PPM in 28 settings.

AOOR / VOOR Modes

The Pinnacle R Model 297 PRO MRI device *delivers* pace stimulus at the rate determined by the activity sensor and the rate response parameters *regardless of any intrinsic heart activity*.

Rates

Basic Rate

The meaning of the **Basic Rate** parameter depends on the operating mode of the implanted device. It can be programmed through the Programmer between 30 and 180 PPM (± 1 PPM) in steps of 2 PPM (± 1 PPM).

Correspondingly, the **Period** can be programmed through the Programmer between 2000 and 333 ms in the steps and accuracy determined by the basic rate

Hysteresis

Hysteresis allows the patient's intrinsic rate to fall below the programmed basic rate without inducing pacing. When the value of this parameter is different from zero i.e. OFF, the implanted device works with two different rates, as follows:

- In the cycles following a paced event, the Basic Rate is applied.
- In the cycles following a sensed event, the basic rate decremented with the programmed Hysteresis percentage is applied.

The Hysteresis parameter can be set through the Programmer between 2 BPM to 40 BPM in steps of 2 BPM.

Sensing The implanted Pinnacle series device can detect electrical signals through the lead implanted in the heart. These signals are then analyzed and, depending on parameter settings, pace stimulus may be delivered or inhibited.

This chapter includes information about the sensing features of the implanted Pinnacle series device.

Sensitivity

The parameters related to heart signal sensing are the Sensitivity. The **Sensitivity Threshold** can be programmed through the Programmer between 0.5 and 7.5 mV.

The Sensitivity is measured according to Standard EN45502-2. The following table shows the relation between the programmed Sensitivity value and the typical Sensitivity value. The tolerance for sensitivity is $\pm 20\%$.

Sensing Polarity

The implanted Pinnacle series devices offer the following sensing configuration options:

- **Bipolar:** signal sensing is done between the tip (distal) and ring (proximal) electrodes of a bipolar lead. In bipolar polarity the device sense heart signals only if the implanted electrode is bipolar.
- **Unipolar:** signal sensing is done between the tip (distal) electrode of the lead and device case.

Refractory Period

The Refractory period is the time interval during which the implanted Pinnacle device does not take into account sensing signals. Signals sensed after a heart event within this period are not considered.

The Refractory Period can be programmed through the Programmer from 200 ms to 500 ms in steps of 15 ms for Pinnacle Model 8820 PRO MRI pacemaker & From 200 ms to 500 ms in steps of 15 ms for Pinnacle R Model 297 PRO MRI pacemaker

Pacing This chapter includes information about the parameters related to the stimuli delivered to the heart by the PINNACLE series implantable devices.

Pulse Shape

The following picture shows the pulse shape in normal conditions.

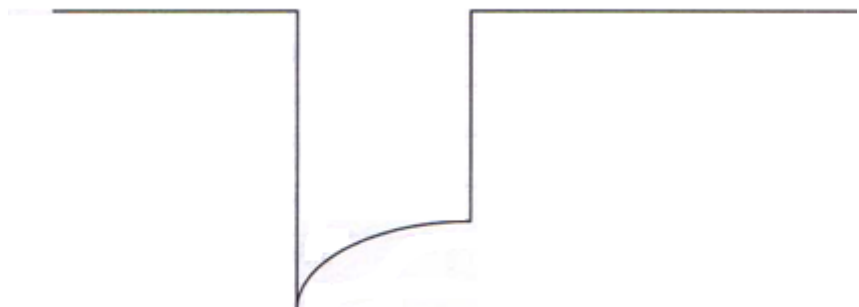

Pulse Width

The **Pulse Width** is the duration of the pace stimulus. It can be programmed through the Programmer at 0.07 ms and from 0.1 ms to 1.5 ms in steps of 0.1 ms.

Pulse Amplitude

The **Amplitude** is the voltage of the pace signal. It can be programmed through the Programmer between 0.2 and 7.5 V.

Pacing Polarity

The **Polarity** of the pace signal can be programmed through the Programmer, to be either Unipolar or Bipolar. Bipolar pacing makes sense only if the implanted electrode is bipolar.

Rate Responsive Parameters Pinnacle R Model 297 PRO MRI (SSI/SSIR) devices contain an activity sensor that can detect acceleration resulting from physical activity. When the implanted device is set in a rate responsive operation mode, patient's physical activity determines an *activity level*, which is used jointly with the rate response parameters to determine the pacing rate in each cardiac interval.

This Chapter includes information about the rate responsive parameters.

Basic Rate

The **Basic Rate** parameter is the rate when the patient is at rest.

It can be programmed through the Programmer between 30 and 120 PPM, in steps of 2 PPM.

Upper Rate

The **Upper Rate** parameter is the upper limit for the pacing rate. Once this rate is reached, an activity increase will not produce an increment in the pacing rate.

The Upper Rate parameter can be set through the Programmer between 80 and 180 PPM, in steps of 2 BPM

Slope

The **Slope** parameter allows determining the Pinnacle R Model 297 PRO MRI implanted device reaction to the activity levels. The higher the Slope parameter value is, the higher rate variation due to activity level alteration will be.

The Slope parameter can be set between 1 and 15, in steps of 1

Reaction Time

Using the **Slope** parameter value, Pinnacle R Model 297 PRO MRI implanted devices determine a new pacing rate goal after each cardiac cycle. In case this new rate is above the current one, the pacing rate will be

increased according to the **Reaction Time (Up Time)** parameter.

Recovery Time

Using the **Slope** parameter value, the PINNACLE R MODEL 297 PRO MRI SSIR implanted device determines a new pacing rate goal after each cardiac cycle. In case this new rate is below the current one, the pacing rate will be decreased according to the **Recovery Time (Down Time)** parameter.

Automatic Refractory Change

When the pacing rate reaches high values due to patient's physical activity, the programmed Refractory Period length can be excessively long, with the corresponding loss of intrinsic events detection. When the **Automatic Refractory Change** parameter is set, the Refractory Period is automatically reprogrammed to 250 ms if refractory value is programmed above 250 ms, whenever the patient's heart period is below 500 ms (that is, when the rate is above 120 PPM).

The **Automatic Refractory Change** can be set through the Programmer.

Diagnostic Features

Impedance

Can be read by programmer

Interference Detection

The pacemaker considers signal above 10 Hz as NOISE. In case of noise detection the pacemaker automatically switches to SOO (asynchronous) mode and programmer displays a message "Noise Detected" on interrogating the pacemaker. If it does not detect any noise signal, it starts working in normal mode

Marker Mode

When marker mode is on, sense or pace event will be displayed on programmer marker window. ECG will also be seen in marker window when ECG electrodes are connected to patients.

Statistics

Data will be displayed of total Pace / Sense Counts, Rate histogram, Impedance values & graphs, Noise count & Noise pacing count.

Threshold Measurement

The pacing and sensing thresholds measurement is done according to the procedure that is detailed in the technical manual of the SPL Programmer. The sensing threshold must be detected in order to assure that the spontaneous pulses will inhibit the pacemaker.

Threshold measurement is available. Pulse width and Pacing Output can be

selected to check Pacing Threshold. Sensing Threshold can also be seen.

It is advisable to check the pacing and sensing thresholds periodically. It is also advisable to have regular controls in the immediate post-implantation period and during the two last years of the pacemaker service life. The Physician should adequately program safe values, that guarantee a correct functioning of the pacemaker according to the patient's needs

Added Parameters

Night Rate

The *Night Rate* function suspends the programmed Lower Rate and replaces it with a night rate (slower than the base rate) during a specified sleep period. The slower pacing rate during the sleep period is intended to reduce the paced rhythm during sleep. Night time and day time can be programmed. Pacemaker is having it real time internal clock. When it detects night time then it replaces the base rate with night rate and when detects day time then it switch back to base rate.

If “Switch to day rate based on Activity” is ON and patient does some activity in the night then pacemaker switches to base rate (or day rate).

Night Rate Programming

Night Rate function is available in all pacing modes and is nominally Off. Additional programming parameters includes:

Night Rate Parameters			
Night Rate	50	<input checked="" type="checkbox"/>	Enable
Night Time	22	:	0
Day Time	6	:	0
<input checked="" type="checkbox"/> Auto Day rate			

- **Night Rate** – Device gradually reduces the pacing rate to “*Night rate*”. Night rate remains in effect until the programmed “*Day Rate Switch Time*”.
- **Night Rate Switch Time** – Time at which base rate will gradually decrease to the “*Night Rate*”.
- **Day Rate Switch Time** – Time at which Night rate will gradually increase to the base Rate.

Rate Drop

Rate Drop rate (RDR) is intended to provide backup pacing in case of occasional episodes of significant drop in heart rate (eg, syncope from cardio inhibitory and mixed forms of carotid sinus syndrome).

This algorithm is designed for patients showing a consistent spontaneous

rhythm (>60bpm) with rare episodes of sudden rate drop during syncope events only. Thus when the RDR algorithm is programmed ON, the basic rate of the pacemaker should be programmed at a quite **low value** (40-45 BPM) in order to avoid competitive stimulation during normal sinus rate and also pacemaker should be able to monitor sinus rate properly.

Rate Drop Programming

Rate Drop Response is nominally programmed Off and is only available when the pacing mode is programmed to VVI & AAI.

To ON rate drop feature, click check box of '**Rate Drop**' in "Features" window.

Rate Drop Programming For Pacemaker

The screenshot displays four programming windows for Rate Drop:

- Features:** Includes checkboxes for VSP, PVC/PMT, NCAP, AF, and a checked box for **Rate Drop**.
- 1st and 2nd Detection:** Shows **12 Beats** for the 1st detection and **3 Beats** for the 2nd detection.
- RD Rate and Duration:** Shows **96 BPM** for the rate and **180 Beats** for the duration.
- Upper and Lower Limit:** Shows **64 BPM** for the upper limit and **50 BPM** for the lower limit.

Note:

Rate Drop condition: "Basic Rate should be less than Lower limit of Rate Drop"

There are two windows (1st & 2nd Detection) to detect and confirm rate drop as below ---

Rate Drop Parameters:

- Rate Drop - ON/OFF
- Rate Drop Rate - 80 to 144 BPM
- Rate Drop Duration - 30 to 240 beats (Step of 30 beats)
- 1st detection Window - 1 to 30 beats (Steps of 1 beat)
- 2nd detection Window - 1 to 7 beats (Steps of 1 beat)
- Upper Limit - 50 to 100 BPM
- Lower Limit - 40 to 80 BPM

The drop in sinus rate (upper limit) is usually not a step but a slope. 1st detection window starts when the sinus rate drops below "**upper limit**". If sinus rate doesn't drop below "**lower limit**" (RDR threshold) then, no RDR

algorithm will be activated and pacemaker keeps on monitoring for rate drop.

If the sinus rate drops below the “**lower limit**” (RDR threshold) rate, the 1st detection window ends and 2nd detection (confirmation) window starts. After confirmation pacemaker activates RDR algorithm in which pacemaker starts pacing at “Rate Drop Rate” for rate drop duration. After Rate drop duration the pacemaker rate drops down to basic rate. The rate drop algorithm cycle as above.

Lead Monitoring

All pacemakers allow clinicians to manually program lead configuration (bipolar or unipolar) for each chamber connected to a bipolar lead. In addition, Pinnacle Plus series pacemakers also incorporate a “**Lead Monitor**” feature. Lead Monitor has two parameters such as ‘**Monitor Only**’ and ‘**Auto Pol SW**’.

“**Lead Monitor**” feature daily measures impedance and keeps record of average impedance value of a month and such last 6 months average impedance values will be stored in the pacemaker & the same can be read in statistics under “Impedance values” tab.

“**Auto Pol SW**” automatically switches the pacing and sensing lead polarity from bipolar to unipolar if the measured bipolar impedance is out of lower (<250 Ω) & higher limits (>2500 Ω).

This feature preserves pacing and sensing through a unipolar polarity following an out-of-limit bipolar impedance measurement. Loose setscrews, lead fractures, or lead abrasions may cause lead impedance values to fall outside of the normal range. If the “**Auto Pol SW**” feature has been activated (programmed ON), Pinnacle series devices will automatically switch to unipolar pacing and sensing when two of the last eight daily impedance measurements are out-of-range.

Implant Data & Patient Info

“**Implant Data**” form is available in pop down menu under “Files” tab. The patients implant information can be saved (write) in the device and can be ‘read’ any time using programmer.

“**Patient Info**” form is also available in pop down menu under “Files” tab. In this form the follow up data / parameters of the patient can be stored in the computer in the form of PDF as well as JPG & the same can be retrieved from the same computer.

Set Date & Time

Pacemaker internal date & time can be synchronized with computers date

& time using this feature. This feature is available in pop down menu under “Tools” tab.

Smart-E programming system with SPL software is the application designed by Shree Pacetronix Ltd. to consult and modify the parameters that rule pacemaker activity belonging to their SSI/SSIR pacemakers.

SPL software, created to be run in a personal computer with Windows operating system, is connected by means of a programming interface to a programming head, which communicates by telemetry to the pacemaker implanted in the patient.

The programming head must be placed over the implant zone, not further than 50 mm from the pacemaker, making sure that the light blinks following its frequency. The button located in the programming head is usually used to "interrogate" the pacemaker, that is, to show in the SPL software screen the programmed values that determine its functioning.

Using SPL software (Smart-E programmer) the Physician may interact with the pacemaker: modify the frequency and duration of the generated stimulus, measure pacing and sensitivity thresholds, study statistics and graphics of the assistance given by the heart stimulator, keep an electronic file of patients and their controls, calculate which is the battery consumption of each program, register standard programs for further use, reprogram the pacemaker in order to quickly control heart rhythm problems, etc.

SPL software offers in a graphic interface of quick and easy handling, all these multiple options which improve the functioning of the pacemakers built by Pacetronix and achieve, in every case, accurate and personalized clinical follow-up.

NOTE: For Programming Details please refer to 'Programming Manual (SMART-E Manual)'

Programming The SMART-E programmer includes:

Package

- Programming Interface, Model:SEP-11
- Programming Head , Model:SEH-11
- USB Cable
- ECG cable

Connections of Programming System



USB Cable Connection

- To PC**
 Connect USB cable (PC end) to USB port of the PC. This will connect programming interface with the PC to powering up the Smart-E programmer system.
- To Programming Interface**
 Connect USB cable (Interface end) to programming interface female connector USB I/O.
 Verify the connection of USB cable from both PC and Interface end.
 Loose connection may cause communication error.

Programming Head Connection

Connect Programming head male connector to programming interface at Female connector Wand.

ECG Cable Connection

- At programmer end**
 Connect ECG cable male circular connector to the programming interface female ECG connector.
- At patient end**
 Connect ECG cable patient end electrode connectors to the patient by using disposable electrodes.

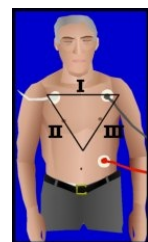

Note: - Make sure that patient's body should be cleaned first before placing disposable electrodes.

Interrogate the Device The first action to be carried out in order to access the information of the pacemaker is Interrogate. After interrogating, the model, serial number, battery condition, and the different programmable parameters are shown on the screen.

Once the programming head is placed over the implant zone, the LEDs blink on the LED bar of head and the interrogation action can be performed in any of the following different ways.

1. Press the Interrogate button on the programming head.
2. Click '**Interrogate**' button of the toolbar (SPL software).
3. Activate the Tool menu and choose the 'Interrogate' option.

If the interrogation is successful, the different parameters of the pacemaker (which vary according to the model) appear on the screen.

Program the Device The Programming action transmits the values that are on the screen to the pacemaker using telemetry. The programming head should be correctly placed on the implant zone (the green LED must blink).

Programming can be performed in any of the following ways:

1. Click on the '**Program**' button in the toolbar.
2. Click on the Tool menu and then choose the '**Program**' option.

If the programming action was performed successfully, the message "Programming OK" will appear, otherwise an error message box will be shown

Physician Manual

8

IMPLANT PROCEDURE

All Surgical procedures and sterile techniques (all surgical equipments & pacemaker) are the responsibility of the physician. Each physician must apply the information in these procedures according to professional medical training and experience.

Opening a Sterile Package

A sterile package contains a Pacemaker & a torque wrench. The term sterile pack refers to a set of inner & outer tray. The pacemaker & wrench is kept inside the inner tray.

Before opening the sterile pack, check for any signs of damage that might invalidate the sterility of the contents. If there is any uncertainty about the sterility, do not implant the pacemaker. Non-sterile pacemakers should be returned to Pacetronix.

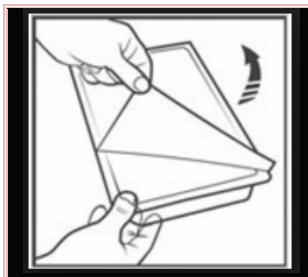

*Figure 1:
Peeling of
pacemaker
tray*

The implant procedure includes the following steps:

- *Verify lead and connector compatibility.*
- *Test the lead system.*
- *Connect the lead to the device.*
- *Test the device operation.*
- *Position and secure the device.*
- *Program the device.*
- *Replace a device.*

Verify lead and connector compatibility

Warning: Verify lead and connector compatibility before using a lead with this device. Using an incompatible lead may damage the connector, result in electrical current leakage, or result in an intermittent electrical connection.

Select a compatible lead. Refer to the following table.

Table 05: Lead and Connector Compatibility

Pacemaker Model	Lead Model	Polarity	Lead Connector
<ul style="list-style-type: none"> Pinnacle Model 8820 PRO MRI Pinnacle R Model 297 PRO MRI 	3851VB PROMRI (Bipolar Lead) 3851AB PROMRI (Atrial J Lead) 3844VB / 3744VB PROMRI (Screw-in Lead)	Bipolar / Unipolar	IS-1* BI / IS-1 UNI

*IS-1 refers to the International Connector Standard (see Document no ISO 5841-3) whereas pacemaker and leads are assured of meeting the electrical and mechanical parameters specified in the IS-1 International Standard.

Lead Implantation

The following is general guide intended for informational purpose only. The physician should add to or alter procedural details with respect to his clinical experiences.

To ensure stable pacing and a long service life for the endocardial lead, it is important to position the lead so as to minimize mechanical stresses and maximize electrical contact with ventricle. Implantation should, therefore be performed in a facility permitting fluoroscopic verification of satisfactory lead and electrode placement.

A number of venous route are available for implanting an endocardial lead, including the cephalic, subclavian and external jugular veins. The (generally, patient's nodominat side is preferred for the pulse generator) pocket requires a single surgical sito for both pacemaker & introduction of lead. Lead complications such as erosion and breakage are more common with the jugular approaches, but for patients with small cephalic veins, these routes may be preferable. After selection of the venous route to be used, open the sterile package. With a straight stylet fully inserted into the lead, introduce the lead into incised vein. Alternatively, a percutaneous lead introducer may be used to introduce the lead into the vein.

Cautiously advance the lead under fluoroscopic observation. Electrode position must meet both mechanical & electrical requirements.

When the electrode is lodged securely under one or more trabeculae, a slight resistance will be felt when the lead is pulled gently. Measure the stimulation threshold (refer '10.4' "Test the lead system") both before and after asking the patient to breathe deeply and cough vigorously. If the readings are similar, it can be assumed that the electrode is anchored adequately.

The lead is supplied with a integral suture sleeve. The suture sleeve is pre-installed on the lead. Once satisfactory threshold & electrode stability have been achieved, slide the suture sleeve into the position at the desired anchor point (generally, at the point of entry of the lead into the vein or subcutaneous tissue if a percutaneous introducer is used). Secure the sleeve to the lead by tying a non absorbable suture between the O rings of sleeve. The suture is tied tight enough to prevent the lead from moving with the sleeve, but not so tight that it might deform the lead's conductor coil.

Following anchoring of the lead, connector pins are inserted into the pulse generator (refer '10.5' "Connect the lead to the device"), carefully observing the polarity. The lead connection is then secured.

Test the lead system

To test the lead system during implant we need Pacing System Analyzer & its cable. Refer Lead Manual for anchoring the lead system.

Connections of lead to PSA using cable are as below
(Refer *figure 2A & 2B*):

Connection between Cable (Banana Pin) & PSA:

- *Red banana pin of cable is connected to red collet of PSA.*
- *Black banana pin of cable is connected to red collet of PSA.*



Figure 2A: PSA to Cable connection

Connection between Cable (Crocodile Pin) & Lead:

- Red crocodile pin of cable is connected to Ring (terminal end) of lead.
- Black crocodile pin of cable is connected to Tip (terminal end) of lead.

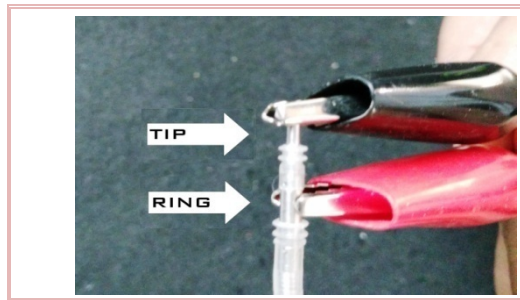

Figure 2B: Lead to Cable connection

A PSA is used to determine the sensing & pacing threshold, Lead impedance. Pacing threshold of less than 1.0 V is recommended and recommended values for the lead impedance is between 400 ohms to 800 ohms. The lowest possible pacing threshold should be sought to assure optimal long term lead & pacemaker operation. If the procedure is being performed under local anesthesia, remove the stylet from the lead and ask the patient to cough and several deep breaths. After this, reconfirm pacing, sensing threshold & lead impedance. A small deviation in threshold & lead impedance values indicates that the lead is well anchored. The lead may now be secured with suture sleeve & connected to the pacemaker (Refer Figure 3).

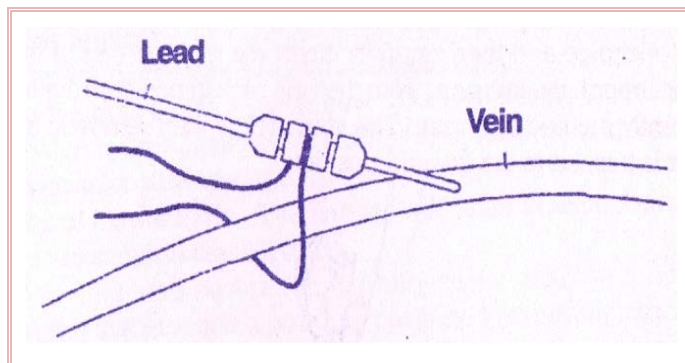

Figure 3:
Lead's suture sleeve
tightens to vein

Connect the lead to the device

Warning: Verify that the lead connections are secure. Loose lead connections may result in inappropriate sensing, which can cause inappropriate arrhythmia therapy or a failure to deliver arrhythmia therapy.

Caution: Use only the wrench supplied with the device. The wrench is designed to prevent damage to the device from over tightening a setscrew.

In order to correctly connect the leads to the pacemaker, you should carefully follow these steps:

- Check that the setscrew is retracted from the terminal block to ensure that lead passage is clear in the lead cavity. If the lead cavity is obstructed, retract the setscrew to clear it. Do not disengage the setscrew from the terminal block, see *Figure 4*
- Introduce the lead until its end crosses over the connector. In case of difficulty when connecting the electrode, spin the screw (counter clockwise) with the wrench (screw driver), lubricate the lead with distilled water or with the provided lubricant jelly. The lead's end can be seen at the connector window.

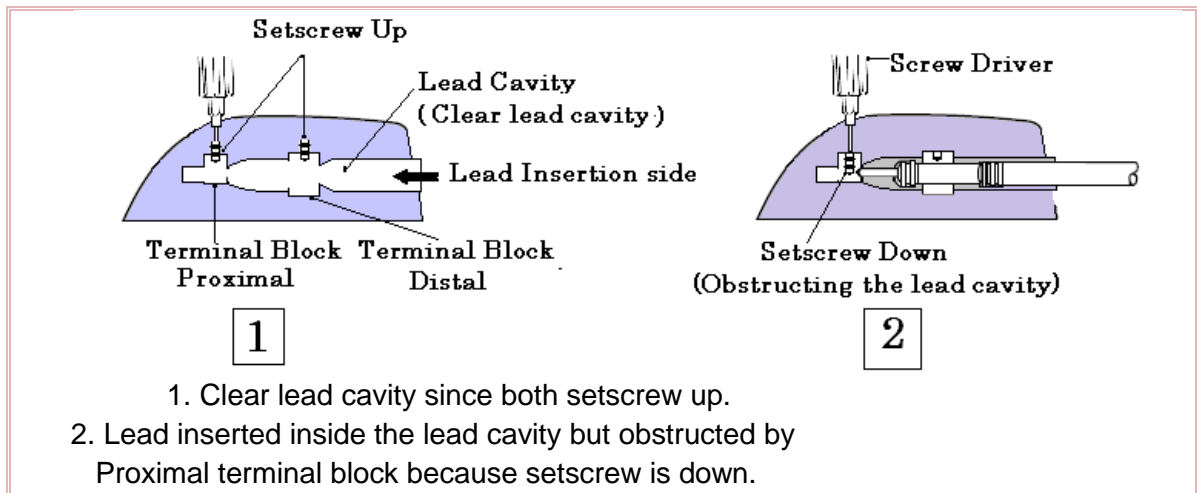
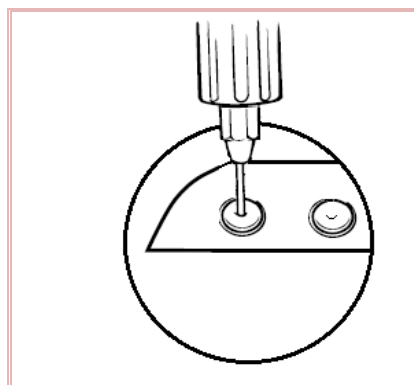

Figure 4: Lead cavity

- The wrench should be introduced in the pacemaker neck through the hole. Leave the wrench in the set screw until the lead is secure. This allows a pathway for venting trapped air when the lead is inserted, see *Figure 5*.



*Figure 5:
Wrench in the
Setscrew*

- Push the lead terminal end into the lead cavity until the terminal pin (Tip) is visible in the lead viewing area. Sterile water may be used as a lubricant. Sealant is not required (see *Figure 6*).

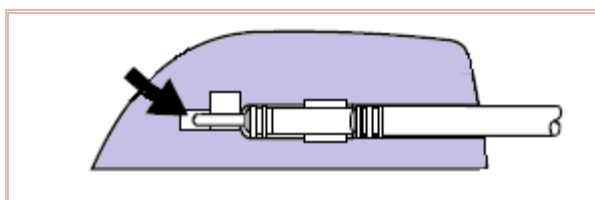

*Figure 6:
Inserting a lead into the
device*

- The lead pin is visible at the end of the viewing area.
- In order to secure the lead, tighten the setscrew by turning the wrench to the right until the wrench clicks (only 2-3 clicks) for both Proximal & Distal end. The stimulation should not start until the screws are firmly adjusted.
- Gently pull on the lead to confirm the connection.
- In order to assure a perfect adjustment, the lead has molded rings; it does not require the use of any additional element for the sealing.

Test the device operation

Warning: Keep an external Pacemaker INDUS SSB 100 available for immediate use. The external pacemaker is used when the lead is disconnected and pacemaker-dependent patients are without pacing support.

Verify device operation by reviewing an ECG. If pacing and sensing are not adequate, perform one or more of the following tasks:

- Verify the connection of the lead to the pacemaker. Confirm that the lead connector pin appears in the viewing area.
- Disconnect the lead from the pacemaker. Visually inspect the lead connector and lead. Replace the lead if necessary.
- Retest the lead. Inadequate electrical signals may indicate lead dislodgment. If necessary, reposition or replace the lead.

Position and secure the device

Warning: Electrosurgical cautery may induce ventricular arrhythmias or may cause device malfunction or damage. If electrosurgical cautery cannot be avoided.

Observe the following precautions to minimize complications:

- Keep temporary pacing and defibrillation equipment available.
- Use short, intermittent, and irregular bursts at the lowest appropriate energy levels.
- Avoid direct contact with the device or leads. If unipolar cautery is used, position the ground plate so the current pathway does not pass through or near the device and lead. The current pathway should be a minimum of 15 cm away from the device and lead.
- Program the device to an asynchronous pacing mode for pacemaker-dependent patients.

Note: Proper device placement can facilitate lead wrap and prevent muscle stimulation. The device may be implanted in right or left pectoral sites. Either side of the device may face the skin to facilitate excess lead wrap.

- a) Verify that Tip & Ring of lead is properly inserted into the proximal & distal terminal block and both setscrews are tight.
- b) To prevent twisting of the lead body, rotate the device to loosely wrap the excess lead length. Do not kink the lead body.
- c) Place the device and leads into the surgical pocket.
- d) Suture the device securely within the pocket. Use non-absorbable sutures. Secure the device to minimize post-implant rotation and migration. Use a surgical needle to penetrate the suture hole on the device.
- e) Suture the pocket incision closed.

Program the device

Use SPL software to interrogate or read the current parameters of the device. Program the device as instructed by Doctor.

If the lead threshold is increased, increase the amplitude or broaden the pulse with accordingly. Amplitude of device should be 2.5 time the lead threshold. If the patient experiences muscle stimulation while being paced in the unipolar configuration, reduce the amplitude or narrow the pulse width. Maintain adequate stimulation safety margins.

Replace a device

See Section, "Position and secure the device"

If you are replacing a previously implanted device, perform the following steps:

- a) Program the device to a non-rate responsive mode (Pinnacle R Model 297 PRO MRI) to avoid potential rate increases while handling the device.
- b) Dissect the lead and the device free from the surgical pocket. Do not nick or breach the lead insulation.
- c) Use a screw driver to loosen the setscrews in the connector port.
- d) Gently pull the lead out of the connector port.
- e) Evaluate the condition of the lead. Check the lead for any damage to the pins. Replace the lead if the electrical integrity is not acceptable or if the lead connector pin is pitted or corroded. Return the explanted lead to Pacetronix for analysis and disposal.
- f) Measure the electrical parameters (Threshold & Lead impedance) at current position of lead. Connect the lead to the new (replaced) pacemaker.
Note: see Section, "Verify lead and connector compatibility".
- g) After confirming acceptable electrical measurements, place the device in the surgical pocket and suture the pocket incision closed.
- h) Return the explanted device to Pacetronix for analysis and disposal.

9 EXPLANT PROCEDURE

There are various important indications for explanting or removal of pacemaker as well as lead as below:

- Infection of device – e.g. Pocket infection
- Erosion of the pacemaker or lead
- Lead fracture
- Lead insulation breakage
- Potential Lead failure
- Chronic pain from the pacemaker/lead, which is not manageable medically.
- Replacement of device at battery EOL
- Location of device in a therapy field i.e. MRI test

Pacemaker battery replacement:

The implantable pacemakers provide significant advance warning about the battery status of your device. When the pacemaker signals that the pacemaker battery is weak, you need to schedule visits to the cardiologist to schedule a pacemaker battery replacement. The pacemaker battery will not immediately stop working after signaling.

What if the Battery Runs Low? The battery of a pacemaker is an integral part of the circuitry. Therefore, the entire device is replaced. Replacing the battery of pacemaker usually goes through the old scar on the chest from the implantation of a pacemaker. When the time comes for the pacemaker battery replacement, the old pacemaker is replaced with a new one, and not just the pacemaker battery. The pacemaker's lead that is attached to the heart is disconnected from the old generator and connected to the new generator. After changing the pacemaker battery, patient should have limited hand movements for a few days. Sometimes the pacemaker's lead will develop problems. In this case, the lead(s) must be replaced. Usually, lead failure is known prior to generator replacement from evaluation of your device. Occasionally, an unknown lead problem is detected during surgery. During pacemaker battery replacement procedure the patient will determine if he wants to go under local or full anesthesia. If a patient chooses a local, his recovery after pacemaker battery replacement is much faster.

Before your Pacemaker Replacement

- Do not eat any food or drink any fluids after midnight the day before your test.
- Anticipate that the entire procedure and recovery time will take two to four hours.

During the Procedure

- One of our nurses will take you to a procedure room and a physician or nurse practitioner will discuss the procedure with you and review your medical history.
- You will be asked to sign a consent form.
- After you change into a hospital gown, an intravenous line (IV) will be placed in your forearm. A blood pressure monitor will be placed on your arm, and ECG stickers will be placed on your chest to monitor your heart rhythm. A defibrillator may be required in emergency.
- You will be positioned in a comfortable upward position on the procedure bed. The nurses will clean the site where your device is with sterile soap and a sterile drape will be positioned from your chin to your toes.
- You will be given sedating medication through your IV. Local anesthesia will be injected under the skin where the pacemaker will be placed.
- During the surgery you will be drowsy. You will be given medication to prevent any discomfort.
- Once the procedure is complete, you will be taken to your hospital room or the recovery room.

Please note: Some patients with pacemakers require the pacemaker for every heartbeat, although most patients are not this dependent upon their pacemakers. For pacemaker dependent patients, a temporary pacemaker, placed, may be used to pace the heart during the brief period between the disconnection of the old pacemaker and the connection of the new one.

Explant and disposal

Consider the following information related to device explant and disposal:

- Explant the implantable device postmortem. Explanting battery-operated implantable devices is mandatory because of environmental concerns. In addition, if subjected to incineration or cremation temperatures, the device may explode.
- Pacetronix implantable devices are intended for single use only. Do not re-sterilize and re-implant explanted devices.
- Please use the Product Information Report to return explanted devices to Pacetronix office for analysis and disposal.

Before you leave the hospital, your doctor will tell you when you need to schedule a follow-up appointment. Follow-up appointments are important to ensure that your pacemaker settings are working well for you. Follow-up procedures such as monitoring battery measurements and confirming therapy parameters are described in the product documentation that is included with the software that supports this device. No surgery is required, and the procedure is painless. The appointment usually takes the same amount of time as a regular doctor's appointment. Follow-up appointments can be done at a clinic or in your doctor's office.

Follow-up information

The purpose of follow-up appointments is to check or monitor the following types of information:

- Assess your general medical condition.
- Check the operation of your pacemaker. This includes checking the battery power and the status of your implanted leads.
- Review the information saved by your pacemaker.
- Adjust your pacemaker settings, if necessary, to provide the best treatment for your heart condition.

Your doctor will review your current medications with you and can answer any questions you have during the visit. Our doctor will tell you how often your pacemaker should be checked. Your first follow-up appointment is usually scheduled for 1 month after your pacemaker is implanted. Depending on your medical condition, additional follow-up appointments are scheduled. More frequent appointments are usually scheduled as your pacemaker nears its expected replacement time.

Reviewing information saved by your pacemaker

During a follow-up appointment in the clinic or hospital, your doctor will use the Pacetronix SPL Programmer to interrogate (read) data collected by your pacemaker or to change the parameters value of your pacemaker. Your pacemaker collects and saves the following information:

- ECG recordings of any unusual heart rhythms.
- A list of parameters changed during pacemaker follow up.
- Status of pacemaker battery.
- Status of your implanted lead.

Based on this information and a review of your medications, your doctor may adjust the settings of your pacemaker to fit your individual needs.

When to call your doctor

Contact your doctor or nurse if you experience any of the following situations:

- You notice any swelling, warmth, or drainage around your incision or if you develop a fever while your incision is healing.
- You notice new, unexplained heart symptoms or if you experience the same heart symptoms you had before receiving your pacemaker.
- You have heart rhythm symptoms that last longer than 3 minutes (or any length of time specified by your doctor).

These symptoms can include extreme fatigue, racing heart, pounding heart, or feeling faint or dizzy.

Caring for yourself

Caring for yourself is one of the most important parts of your follow-up care. Talk with your family and caregivers about how you are feeling, and share the information in this manual with them so that they can help you return to your normal activities.

Give yourself and your family a few months to adjust to living with your pacemaker. Most people report that they have a wide range of emotions after receiving a pacemaker. It is natural and normal to feel a little cautious and nervous about how your pacemaker will affect your life.

With time, your confidence will return as you get back to your normal activities and family life. Addressing your concerns and having a positive attitude toward your pacemaker and the therapies it provides can enhance the quality of your life over the long term.

Dealing with anxiety and getting the support you need

After receiving a pacemaker, many people report a positive change with feelings of relief, comfort, and well-being. Yet, experiencing feelings of anger, fear, and guilt are also natural and expected. You may want to talk with your doctor or nurse about anything that is causing you to worry.

What is one common source of stress for pacemaker patients and families?

A common worry pertains to the pacemaker performance. Shree Pacetronix Ltd. pacemakers are extremely reliable, and most patients feel that their quality of life improves after the implant because the pacemaker can effectively relieve the troubling symptoms. Yet, at times, you may worry about whether the pacemaker will work when needed. Follow-up appointments help monitor the performance of your pacemaker and provide you with an opportunity to ask questions. With that comes comfort and reassurance, thus reducing the anxiety.

What are some other ways to relieve stress and get answers to my questions?

It often helps to talk with other people who have a pacemaker and ask them how they have adjusted to it. Ask your doctor or nurse if there is a support group for pacemaker patients at your clinic or a nearby hospital.

In addition, company's websites provide information you may find helpful:

- Device Manuals.
- Contact information.

Medical care

- Follow your doctor's instructions about diet, medications, and physical activity.
- Attend all pacemaker follow-up appointments and other general health checkups.

Planning for an emergency

Because you have a pacemaker, it is important to be prepared in case of any emergency. Talk to your doctor about planning for emergencies. They may suggest that you develop a plan with your family and friends that includes the following points:

- Carry your pacemaker ID card in an easy-to-find place such as a wallet.
- Carry a list of medications and dosages.
- Keep emergency phone numbers in an easy-to-find place.
- Inform significant coworkers, traveling companions, and so on, that you have a pacemaker.
- When traveling by air, inform airline security personnel that you have a pacemaker.

You may also want to post information that you want to have readily available near your phone.

What your family and friends should know

Your family and friends can be a big support for you during your hospital stay and after you get home. Encourage them to learn about your pacemaker and about how they can continue to support you.

If your family or caregivers have any questions or concerns, have them call your doctor. They may also want to attend support group meetings with you.

User Manual

Why the heart is sometimes described as a pump?

Your heart's job is to deliver oxygen and nutrients to all the organs and tissues of your body. Your heart does this by pumping blood from the lungs (where it picks up oxygen) to all the areas in your body (where it drops the oxygen off). The heart then pumps blood back to your lungs, completing the loop that keeps you alive day and night year after year. A normal, healthy heart automatically regulates its own heart rate.

What does the heart look like?

Your heart is divided into four connected chambers, each with a part to play in pumping blood. Oxygen-poor blood from the body enters the heart at the right atrium.

When the atrium is full, it pumps the blood into the chamber below it, which is called the right ventricle. This larger chamber squeezes the blood out of the heart and into the pulmonary artery that takes the blood to the lungs.

After picking up oxygen, the blood returns to the heart through the pulmonary veins into the left atrium. When the left atrium is full, it pumps the blood into the large chamber below it. The left ventricle then uses its strong muscles to pump blood into the body.



How does the heart beat?

The millions of cells in your heart react to small pulses of electricity. Your heart makes its own electrical pulses in a special area at the upper part of the heart called the Sinoatrial Node or SA Node. (See below)

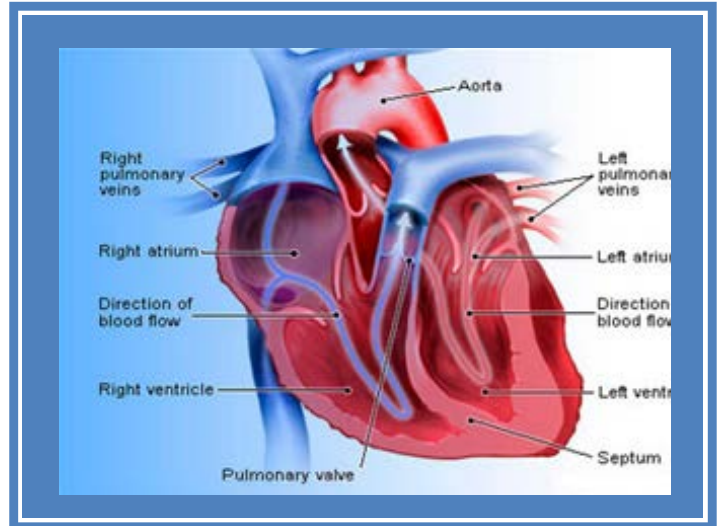

What does the heart look like?

Your heart is divided into four connected chambers, each with a part to play in pumping blood. Oxygen-poor blood from the body enters the heart at the right atrium.

When the atrium is full, it pumps the blood into the chamber below it, which is called the right ventricle. This larger chamber squeezes the blood out of the heart and into the pulmonary artery that takes the blood to the lungs. After picking up oxygen, the blood returns to the heart through the pulmonary veins into the left atrium. When the left atrium is full, it pumps the blood into the large chamber below it. The left ventricle then uses its strong muscles to pump blood into the body.

How does the heart beat?

The millions of cells in your heart react to small pulses of electricity. Your heart makes its own electrical pulses in a special area at the upper part of the heart called the SA node.

How often does the heart beat?

A normal heart beats 60 to 100 times each minute, regularly and in rhythm, so the time between each heartbeat is roughly the same. Depending on the body's need for oxygen, the heart can beat faster or slower. Your body tells your heart how much oxygen it needs.

What is the Sinoatrial (SA) Node?

The SA Node is a cluster of specialized cells in the atrium that produces tiny electrical signals and sends them to the rest of the heart. The SA Node senses when the atrium fills with blood and sends out an electrical pulse that causes the muscles in the atrium to contract. This contraction pushes the blood in the atrium down into the ventricle.

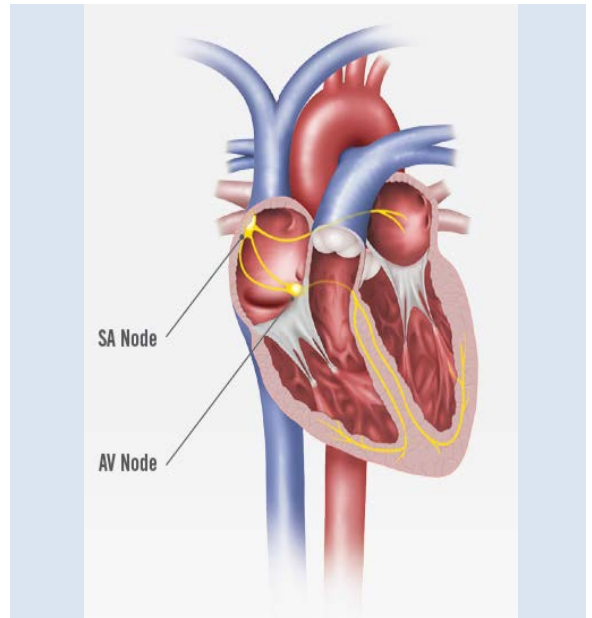

What is the Atrioventricular (AV) Node?

The AV Node or Atrioventricular Node is another specialized cell cluster, located between the atrium and the ventricle. It holds the pulse for just a few hundredths of a second before releasing it into the ventricle.

The result is that the atrium beats first, pushing blood into the ventricle, and then the ventricle beats after it has been filled with the blood from the atrium.

ARRHYTHMIAS

Arrhythmias

- **What is an arrhythmia?**

An *arrhythmia* (pronounced “a-RITH-me-a”) is any abnormal heart rhythm. It could be irregular, too fast, or too slow.

- **What are the different kinds of arrhythmia?**

Too Slow—Bradycardia

Bradycardia means “slow heart.” A heart that beats too slowly all the time can make a person tired, dizzy, or lightheaded because a slow heart is not pumping enough blood to provide the body with as much oxygen as it needs. A *pulse generator* can be used to make a person’s heart beat normally.

Too Fast—Tachycardia

Tachycardia means “fast heart.” If the heart beats too fast all the time, its chambers may not fill completely with blood. The heart will not be able to pump enough oxygen to the body and the result will be dizziness, fainting, and even cardiac arrest. Some tachycardias occur in the top chambers of the heart and some occur in the lower portion.

Ventricular Fibrillation

This is the most serious kind of arrhythmia, where the heart’s electrical signals aren’t timed correctly and start in the ventricle instead of the SA Node. The result is that the heart “fibrillates” or quivers instead of beating regularly. A fibrillating heart pumps very little blood to the body, and a person in ventricular *fibrillation* quickly loses consciousness.

To treat ventricular fibrillation, doctors use *de-fibrillation*, which is a large electrical shock to the heart that returns the heart to its normal rhythm. The shock can come from a machine with large paddles, or it can come from an *ICD* (Implantable Cardio Defibrillator) implanted within the body.

Atrial Fibrillation

This is the most common arrhythmia in older people. In atrial fibrillation, the upper chambers of the heart are quivering (or “fibrillating”) and the signals sent to the lower chambers are irregular and erratic. Some people may not feel any effects of atrial fibrillation. But in many people, this arrhythmia causes a feeling of pounding or fluttering in the chest. It may make people feel tired, sluggish, dizzy, or short of breath.

More serious is the fact that atrial fibrillation can cause a blood clot inside the heart that can flow to any part of the body, where it can cause a stroke or embolism.

Doctors can treat atrial fibrillation with a combination of surgery, medications, and defibrillation. Pulse generators can also be used to treat some patients with atrial fibrillation, depending on the cause and type of arrhythmia.

Other Arrhythmias

Besides beating too fast or too slow, the heart can also beat irregularly. For example, one side of the heart may contract sooner than the other side. When this happens, blood and oxygen are not delivered fast enough to the body and the pumping mechanism begins to fail. If blood is not pumped out of the lungs and the body, it backs up, causing congestion like a traffic jam.

This can lead to a serious condition called *congestive heart failure*. This condition is usually treated with drugs, but in some cases, a special kind of pulse generator can be used to help in the treatment.

- **What causes arrhythmias?**

Many conditions and substances affect the heart's rhythm. Diseases like diabetes, hypertension, heart disease, chronic obstructive pulmonary disease, and hyperthyroidism can cause arrhythmias. Alcohol and certain drugs can cause arrhythmias, and so can drug withdrawal. Some people are born with hearts prone to arrhythmias. Some people have their heart's electrical system damaged by a heart attack or poisons. Even emotional swings, caffeine, and pregnancy affect the heart. Finding the cause of an arrhythmia is important because the treatment depends on the cause. Your doctor may order tests and procedures to diagnose the cause of your arrhythmia

What is a pulse generator (PG)?

A pulse generator can recognize a problem with your heart's rhythm and send out its own electrical pulse to make your heart beat regularly and on time. (A pulse generator *generates* or makes a pulse.) It is made up of computer chips and a small, but long-lived battery in a sealed case.

The pulse generator is surgically implanted in the upper chest or abdomen. (The operation is described on page 23.) The pulse it generates is sent through special wires called *leads*, normally placed inside the heart. The lead also helps the pulse generator sense the heart's rhythm. This is important because the device must send out its pulse at a precise moment.

Why do I need a pulse generator?

If you have a slow or abnormal heart rate that causes fainting, dizziness, tiredness, shortness of breath, palpitations, or loss of consciousness, you may need a pulse generator. In many cases, a pulse generator can help your heart beat properly.

How does the pulse generator know when to pulse?

The pulse generator can sense the heart's rhythm. Pulse generators can be "programmed" to either send out a pulse or to wait for the heart to beat on its own. Some pulse generators also sense the patient's activity — for example, climbing stairs or exercising — so that it can speed up or slow down the heart rate.



After a pulse generator is inside the body, its settings can still be changed. Doctors and clinicians "talk" to it with a *programmer*. This is a computer with a wand that sends signals through the body to the pulse generator. The procedure is painless. The programmer also displays information the pulse generator has collected about the heart.

What does a pulse feel like?

Most people can't feel it at all. The electrical pulse of a pulse generator is very small. If you do feel a pulse, your doctor or clinician may change the settings to make you more comfortable.

What happens when the battery runs down?

A pulse generator normally lasts from five to ten years. How long it lasts depends on the type of battery, how often it sends a pulse, the patient's medical condition, and other factors.

The battery does not suddenly stop working. It gradually runs down over a period of months, usually with more than enough time to schedule a replacement.

Doctors and clinicians check the battery at each follow-up visit. When the battery energy gets low, the pulse generator has to be replaced with a new one, and you must have another operation.

Types of Pulse Generators

The first pulse generator in the 1950s was the size of a hockey puck. Its battery lasted less than a year. Today, pulse generators are much smaller. They now can stimulate up to three chambers of the heart and their batteries last between five and ten years.

The simplest pulse generators today are called single chamber pulse generators because they are connected to one lead in one chamber of the heart, usually the right ventricle.

The pulse generators can also be *rate-modulated*. That means the pulse generator can speed up when the patients becomes more active and slow down when the patient is resting. Also known as "rate responsive" or "rate-adaptive," this type of pulse generator has a sensor so it knows when the patient is moving. For example, a rate-modulated pulse generator will speed up when a person jogs. When the person stops to rest, the pulse generator slows the heart rate.

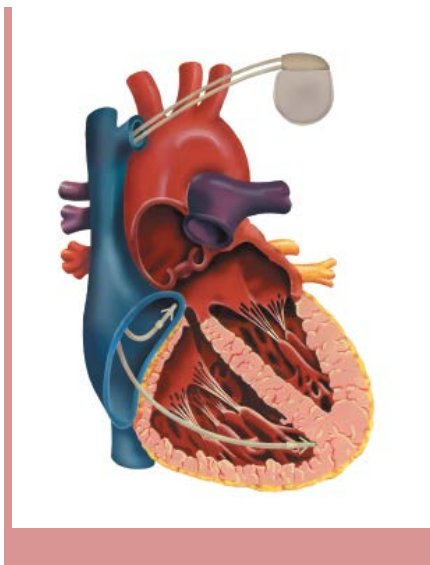

Doctors prescribe different pulse generators for different patients. Before implanting a pulse generator, the doctor may conduct tests to tell which pulse generator is best for you.

Pulse generators are not a cure for heart disease. They don't treat the causes of slow or irregular heartbeats. But because they can keep the heart pumping for years, pulse generators can greatly improve the quality of life for people with arrhythmias.

What are the benefits of having a pulse generator?

A pulse generator improves the ability of the heart to pump regularly and on time. Some people must rely completely on the pulse generator to make the heart beat.

Many patients get relief from symptoms such as lightheadedness, dizziness, and fainting. Some people feel they have more energy.

A pulse generator also gives many patients "peace of mind." They feel safer because the pulse generator can keep their hearts beating.

What are the risks of having a pulse generator?

A small number of patients develop complications from the operation to implant the pulse generator and the leads in the body. These can include infection, a reaction to a drug used during surgery, blood loss, or damage to a blood vessel, the heart wall, or other organ. These complications can usually be corrected or cured.

Modern pulse generators have many safety features. Sometimes, a pulse generator may not act properly because it is being affected by outside sources of electromagnetic energy. (Refer, "18 Electromagnetic Interference")

It is also possible for the tip of the lead to shift in the heart so that the pulse is no longer effective. Very rarely, the device may slip out of the "pocket" in the chest. (See the section on surgery below)

Finally, remember these are man-made devices. It is important to monitor the device regularly with follow-up visits as often as your doctor recommends.

Contact your doctor if :

- You notice you are tired, short of breath or your heart rate is changing.
- You notice the wound is red, hot, swollen. More painful or beginning to drain fluid.
- Symptoms you had before the pulse generator was implanted seem to return.

What will the operation be like?

Over two million people have been given pulse generators. By now, surgery to implant a pulse generator is routine. In many cases, the operation takes one to two hours, and patients go home the same day.



However, each patient is unique, and the surgery will differ from person to person. The following sections discuss what generally happens to patients during a pulse generator operation. Your doctor will give you details about what will happen during your own surgery.

What happens before the operation?

Before the surgery, your doctor will tell you how to prepare for the operation. You may have to stop taking one or more of your medications beforehand.

Usually, patients are asked not to drink or eat for several hours before the operation. A technician may take a blood sample. Some doctors will also ask patients to complete insurance and other forms.

What happens on the day of the operation?

You will be taken to an operating room where a nurse or clinician will shave and wash your upper chest or abdomen. You may have an IV (*intravenous*) line placed in your arm and a blood pressure cuff around your arm. ECG (*electrocardiogram*) electrodes will be placed on various parts of your body.

Most patients stay awake for the procedure, and receive a shot of a *local anesthetic* to numb the area where the pulse generator will be placed. If you are going to be given *general anesthetic*, an anesthesiologist will give you medications to put you to sleep.

What happens during the surgery?

After the skin of the shoulder or chest is cleaned and numbed with an anesthetic, the doctor makes a cut through the skin about one to two inches long. The doctor then finds a vein and threads the lead directly into the heart, using a fluoroscope to see where it will go. You should not feel the leads in your heart.



The doctor then makes a small “pocket” under the skin. The doctor fits the pulse generator into the pocket and connects it to the leads

The pulse generator is then tested to make sure it is working properly. You may feel some pressure while the pulse generator and leads are being inserted. If you begin to feel increased discomfort, let the doctor know immediately.

What happens after surgery?

You will be taken to a recovery room where nurses will look after you to make sure you are doing well. You may feel some soreness where the pulse generator was implanted. You will be given pain medication if you need it.

Later on, the doctor or clinician will test your pulse generator to make sure it is working properly.



Many patients go home the same day. Other patients may need longer to recover and will stay overnight before going home.



What will happen when I get home from the hospital?

For the first few days or weeks after your operation, you will need to recover. The wound should gradually heal. You should feel better. At first, you may be aware of the pulse generator, but after a while you will not notice it.

Right after the operation, you should:

- Keep the wound clean and dry. If you notice that the wound is red, hot, swollen, more painful or starts to drain fluid, call your doctor immediately.
- Follow the instructions about bathing, changing the wound dressing and resuming activities.
- Use only gentle movements with the arm closest to the pulse generator. Avoid stretching, lifting, and sudden, jerky movements. As you heal, gradually increase the use of your arm.
- Do not play with or move the pulse generator under your skin. Try not to hit it or bump into it.
- Keep your doctor appointments.
- Keep your pacemaker identification card with you at all times.
- If your symptoms do not improve, call your doctor. Do not wait for a follow-up visit.

What happens at follow up visit?

Refer "13. Follow Up Care"

When can I get back to my old life?

Each person's recovery period is different, but eventually, you may be able to return to your normal life with very few changes.

Your wound should be completely healed before you return to your usual daily activities. Talk to your doctor about how soon you can return to work, drive your car, begin exercising, or go away on a trip.

What is a Pulse Generator Identification Card?

This card lets everyone know that you have a pulse generator. It contains information on the type of pulse generator you have and other important information. If you're ever in a medical emergency, this card will give emergency personnel critical data that could save your life. Keep it with you at all times.

Will a pulse generator limit the things I do?

One of the reasons for getting a pulse generator is to help you lead a fuller life. At home, most people will have no restrictions on their activity. If you work with heavy electrical equipment that causes *EMI*, tell your doctor.

What is EMI?

EMI means *electromagnetic interference*. Certain types of electrical or magnetic energy can interfere with your pulse generator's operation. You should do your best to avoid some major causes of EMI, explained below.



What causes EMI?

- EMI or electromagnetic interference can be caused by:
- Electrical appliances in poor condition or not grounded correctly.
- Electrical equipment that produces a great deal of energy, like industrial generators.
- Arc-welders.
- Medical equipment including MRI devices (magnetic resonance imaging), therapeutic radiation (such as cancer radiation therapy) and TENS (transcutaneous nerve stimulation).
- Metal detectors and security systems used in stores and airports.

What electrical equipment is safe to use?

Most home appliances in good working order are safe to use. This includes microwave ovens, blenders, toasters, electric knives, televisions, VCRs, electric blankets, stoves and garage door openers.

Office equipment and most medical equipment is also safe to use. The pulse generator will work properly during chest and dental x-rays, diagnostic ultrasound, CT scan, mammography, and fluoroscopy.

What should I do if I am near a source of EMI?

In most cases, you can just walk away from the EMI source or turn it off. At airports, show the security personnel your pulse generator identification card so that you do not have to walk through the metal detector.

If you feel symptoms after being near an EMI source, contact your doctor.

What if I am going into a hospital or clinic?

Tell the hospital personnel that you have a pulse generator before you undergo any medical or dental procedure or test.

Do not enter areas that have a “no pacer” symbol posted.

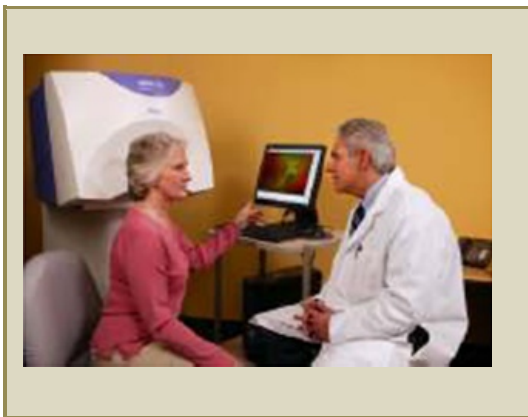

Talk to your doctor if you have to undergo the following medical procedures:

- Electrosurgery
- Electrocautery
- External defibrillation
- Lithotripsy
- Radiation therapy

Do not undergo any diathermy procedure, even if your pacemaker has been turned off. It could cause damage to the tissue around the implanted electrodes, or permanent damage to the pulse generator.

Will a cellular phone interfere with my pulse generator?

You can use a cellular phone without any problems with most pulse generators. Ask your doctor about using a cellular phone.



What about security systems?

Security systems, like the ones used at entrances, exits, or checkout counters are also sources of EMI. When you enter or leave a place with security system, walk through the entrance or exit at a normal pace. Do not linger in these areas.

Are there any precautions I need to take at home?

It is safest to live in a home that has a properly grounded electrical system, so three-prong plugs fit right into the wall. Poor grounding can cause EMI.

Keep your tools and appliances in good running order. Don't use products with breaks in the power cords. If you're fixing your car, remember that your car's electrical system can be a source of EMI.

Some stereo speakers contain large magnets which can interfere with the pulse generator.

Electric razors, vibrators, or hand tools held directly over the pulse generator may affect its operation. Some pulse generators respond to pressure, so your doctor may tell you to avoid sleeping on the pulse generator.

What about sports and recreation?

In most cases, your pulse generator will not limit your fun. However, avoid rough contact sports that might damage your pulse generator—like football, soccer or rugby. It's also best to avoid activities that involve severe shaking, like horseback riding or bumper cars. Strenuous or repetitive upper-body exercise, like weight lifting or softball, can in some cases affect your pulse generator or leads.



Before you begin any vigorous exercise or activity, talk to your doctor.

What precautions should I take at work?

If you work near large sources of EMI (see list above), you should discuss this with your doctor and employer. You may be able to limit your exposure to these sources.

Magnets, large heaters, and radio transmitters can also cause EMI. Work that involves severe shaking or physical contact should also be avoided.

Device operation

Crosstalk – Crosstalk may cause the device to self-inhibit, which results in no pacing. Program the pacemaker to asynchronous mode to prevent inhibition due to crosstalk.

Lead compatibility – Do not use another manufacturer's leads without demonstrated compatibility with Pacetronix devices. If a lead is not compatible with a Pacetronix pacemaker, the result may be undersensing of cardiac activity or a leaking or intermittent electrical connection.

Lead connection – Consider the following information when connecting the lead and device:

- Cap abandoned leads to avoid transmitting electrical signals.
- Plug any unused lead ports to protect the device.
- Verify lead connections. Loose lead connections may result in inappropriate sensing and failure to deliver arrhythmia therapy.

Rate responsive modes – Do not program rate responsive modes for patients who cannot tolerate rates above the programmed Lower Rate. Rate responsive modes may cause discomfort for those patients.

Pacemaker-dependent patients

Inhibit function – Use caution when using the programmer to inhibit pacing. The patient is without pacing support when pacing is inhibited.

Polarity override – Do not override the polarity verification prompt with bipolar polarity when a unipolar lead is connected. Overriding the polarity verification prompt results in no pacing output.

Threshold Test and loss of capture – Be aware that loss of capture during a threshold test. Reduction in amplitude indicates an inadequate stimulation safety margin.

Sensitivities at which Interference may be expected

If the programmed Sensitivity value is less than or equal to 2 mV, the Pinnacle series implantable device may be influenced by electromagnetic interference as represented by the test signals described in clause 27.2.103.1 of the European Standard PR-EN-45502-2-1.

Cremation and Incineration

The Pinnacle series implantable device contains a sealed chemical power cell. For this reason, never incinerate a Pinnacle series implantable device; be sure that the device is explanted before a deceased patient is cremated.

Reuse

A Pinnacle series implantable device that has been explanted for any reason must not be reused for implantation in another patient

Myopotential

The operation of the Pinnacle series implantable device can be influenced by myopotential. This is more likely to occur in case of unipolar configurations at maximum Sensitivity settings. Sensing myopotential may cause occasional ventricular inhibition or reversion to the asynchronous operation.

To control myopotential sensing, the physician may program the Sensitivity parameter with a high value and/or bipolar polarity.

Muscle Stimulation in unipolar configurations

Under certain circumstances (a break in the insulative coating, high output setting, etc), pacemaker-induced muscle stimulation may occur at the pocket site of the implanted device. To control pacemaker-induced muscle stimulation, the physician may program the Amplitude to a minor value

Random Failures

Please take into account that the Pinnacle series implantable devices may unexpectedly fail or stop working at any time due to either random components failure, or battery malfunction. The pacing system may also stop working due to Lead-related problems, such as displacement, fracture, fibrotic tissue formation, etc.

The operation of the Pinnacle series implanted devices may also be affected by Electrical energy.

Environmental Hazards

The following discussion reflects the company's guidance with respect to patient safety in the presence of potential environmental hazards, design features incorporated in the Pinnacle series implantable devices are intended to minimize susceptibility to such hazards, but complete immunity is not possible.

Handling and storage instructions

Follow these guidelines when handling or storing the device:

Checking and opening the package – Before opening the sterile package tray, visually check for any signs of damage that might invalidate the sterility of the package contents.

If the package is damaged – The device packaging consists of an outer tray and inner tray. Do not use the device or accessories if the outer packaging tray is wet, punctured, opened, or damaged. Return the device to Pacetronix office because the integrity of the sterile packaging or the device functionality may be compromised. This device is not intended to be resterilized.

Dropped device – Do not implant the device if it has been dropped on a hard surface from a height of 30 cm (12 in) or more after it is removed from its packaging.

Use by date – Do not implant the device after the “Use by” date on the package label. Battery longevity may be reduced.

For single use only – Do not resterilize and reimplant an explanted device that has been contaminated by contact with body fluids.

Sterilization – The Company has sterilized the package contents with ethylene oxide before shipment. This device is for single use only and is not intended to be resterilized.

Device storage – Store the device in a clean area, away from magnets, kits containing magnets, and sources of electromagnetic interference. Exposing the device to magnets or electromagnetic interference may damage the device.

Temperature limits – Store and transport the package between 4 °C and + 52 °C (40 °F and 125 °F). Device longevity may decrease and performance may be affected at temperatures above +52 °C (125 °F).

Device temperature – Allow the device to reach room temperature before it is programmed or implanted. Device temperature above or below room temperature may affect initial device function.

As with any implantable pulse generator, the pinnacle series pacemakers can be affected by magnetic, electrical and electromagnetic signals of sufficient strength or with characteristics that mimic cardiac activity. In most cases, interference will be detected by the device and cause asynchronous pacing. In more rare occasions interfering signals could cause loss of pacing. Certain sources couple sufficient energy into the device to damage the device's circuitry and/or cardiac tissue adjacent to the electrodes.

The susceptibility of a particular unit will also depend on the location of the pocket created that contain the device the nature of the interference, and the programmed operating parameters. To minimize the effects of the interference, it is recommended to use bipolar sensing and select the highest value for the Sensitivity threshold compatible with a reliable sensing.

Because of the diversity of potential causes of electromagnetic interference, Pacetronix cannot characterize and describe within this manual the effects of all potential sources of interference. Patients should be advised to be cautious when in the vicinity of devices that generate electrical or magnetic fields and seek medical advice before entering an area posted against entry by patients implanted with pacemakers (or other medical implantable devices).

The Pinnacle pacemakers are made using shields, filters and integrated circuits (IC) that assure the immunity to interference from the most common electromagnetic energy sources. However, there can be interference with similar characteristics to the R or P wave. If these conditions are present, the Atrial and/or Ventricular channels can be inhibited.

In presence of continuous interference with a rate exceeding 10 Hz, pacemaker will switch to an asynchronous mode. In case that the patient is usually exposed to interference, it is convenient to use bipolar sensing.

High magnetic fields can activate the magnetic switch, thus, the pacemaker will function as if a magnet is applied. When the electric or magnetic interference ends, the pulse generator goes back to its previous mode.

The following are the most typical interference sources at the medical, work and home environment.

MEDICAL ENVIRONMENT

The studies done through X ray diagnostic and fluoroscopic radiation do not affect the pacemaker functioning.

HOME AND WORKING ENVIRONMENT

Laboratory tests show that the pulse generator is not affected by normal electrical equipment, as for example electrical appliances. Some kind of anti-robbery equipment can inhibit or interfere the pacemaker.

When the patient has to be in contact with high voltage or electromagnetic fields it is advisable to consult the technical coordinator of the company on 24 hour fax no. 07292 400418 and Email: pacetronix@hotmail.com

ELECTROCAUTERY

Surgical use of electrocautery can cause the Pinnacle series implantable devices to pace asynchronously or to inhibit pacing. If sufficient energy is coupled into the system, the unit may be damaged. Application of electrocautery in close proximity to an implanted Pinnacle series device can also cause a direct coupling of radio-frequency energy through the lead and electrode to the cardiac muscle tissue, producing burns or, possibly, cardiac arrhythmias.

The unipolar electro surgery cauterization can inhibit the pulse generator. However, the required levels for inhibition vary considerably according to the type of electrosurgery unit used, according to the current drain, the generator, and the wiring. If it is necessary to use electro surgery equipment, it is preferable to use a bipolar one.

If electrocautery is used, it should be applied in short bursts, with the ground plate positioned so as to minimize current flow through the implanted device and its lead system. If the patient is not pacemaker dependent, it is recommended to program the device to OVO/OAO Mode. The patient's peripheral pulse and ECG should be monitored throughout the treatment, and the implanted device should be checked for proper operation immediately following the procedure. In the unlikely event that an operational abnormality is detected, lead repositioning (replacement) and/or device reprogramming (or replacement), may be indicated.

RF ABLATION

RF Ablation can cause the implanted Pinnacle series device to pace asynchronously or to inhibit pacing. If sufficient energy is coupled into the system, the unit may be damaged. Application of RF ablation in close proximity to the electrodes of an implanted Pinnacle series device can also cause a direct coupling of radio-frequency energy through the leads and electrodes to the cardiac muscle tissue, producing burns, or, possibly, cardiac arrhythmias.

If RF ablation is necessary, it should be applied with the ground plate positioned so as to minimize current flow through the implanted device and its lead system. Avoid direct contact between the ablation catheter and the implanted device and its lead system. If the patient is not pacemaker dependent, it is recommended to program the device to OVO/ OAO Mode, The patient's peripheral pulse and ECG should be monitored

throughout the treatment, and the implanted Pinnacle series device should be checked for proper operation immediately following the procedure. In the unlikely event that an operational abnormality is detected, lead repositioning (or replacement) and /or device reprogramming (or replacement), may be indicated.

MEDICAL DIATHERMY (Short Wave Thermal Induction)

Medical diathermy is generally contraindicated for patients implanted with active medical devices. The operation of the Pinnacle series implantable device subjected to the intense fields of energy involved in this procedure cannot be predicted. Although damage to either the circuitry of the device or cardiac tissue is improbable, it cannot be ruled out.

If medical diathermy must nevertheless be used, it should be applied away from the immediate vicinity of the implanted device and its lead system. If the patient is not pacemaker dependent, it is recommended to program the device to OVO/OAO Mode. The patient's peripheral pulse should be monitored throughout the treatment, and the implanted PINNACLE series device should be checked for proper operation immediately following the procedure. In the unlikely event that an operational abnormality is detected, lead repositioning (or replacement) and /or device reprogramming (or replacement), may be indicated.

DEFIBRILLATION

Any implanted active medical device can be damaged by cardiac defibrillation procedures. In addition, the defibrillation current can cause damage to cardiac tissue adjacent to the electrodes and/or to tissue surrounding the pulse generator, leading to possible alterations in threshold. The defibrillation current may also cause the implanted PINNACLE series device to pace asynchronously or to inhibit pacing. If sufficient energy is coupled into the system, the unit may be damaged.

Although no paddle placement can eliminate the possibility of damage, to reduce its likelihood, it is recommended that the paddles be placed as far from the implanted device as possible. In addition, paddle placements that put the implanted device in the direct path of defibrillation current flow should be avoided.

Following defibrillation, the implanted Pinnacle series device should be interrogated and tested. In the unlikely event that an operational abnormality is detected, lead repositioning (or replacement) and /or device reprogramming (or replacement) may be indicated.

THERAPEUTIC RADIATION

Therapeutic equipment that produces ionizing radiation, such as linear accelerators and cobalt machines used in cancer treatment, can damage the type of circuitry used in most active implantable medical devices. Since the effect is cumulative, both dose rate as well as total radiation dosage determines whether, and to what extent, damage will occur. Please note that any damage to the device may not be immediately detected.

In addition, the electromagnetic fields generated by some therapeutic machines, as part of the energy “steering” process can effects of radiation therapy are cumulative and can range from temporary disturbance to permanent damage. Therefore, if such therapy is used, the implanted device should be protected with local radiation shielding, and its performance should be monitored during and after treatment. If tissue near the implant site must be irradiated, it may be advisable to relocate the Pinnacle series implantable device. During the course of treatment, the implanted Pinnacle series should be interrogated and tested to ensure proper performance. Please consult with Pacetronix prior to exposing a patient implanted with a Pinnacle series device to therapeutic ionizing radiation.

NUCLEAR MAGNETIC RESONANCE (NMR) / MAGNETIC RESONANCE IMAGING (MRI)

The strong static magnetic fields, as well as electromagnetic signals used in NMR/MRI can cause the implanted Pinnacle series device to pace asynchronously or to inhibit pacing. In addition, although permanent damage to the circuitry of the device is improbable, it cannot be ruled out. It is preferred that patients implanted with a Pinnacle series device not be exposed to this type of equipment. However, if NMR/MRI is required, and if the patient is not pacemaker dependent, programming the device to OVO/OAO Mode reduces the possibility of adverse effects. The Patient's peripheral pulse should be monitored throughout the treatment, and the implanted Pinnacle series device should be checked for proper operation immediately following the procedure. In an unlikely event, an operational abnormality is detected, lead repositioning (or replacement) and /or device reprogramming (or replacement) may be indicated.

LITHOTRIPSY

Direct Exposure of a Pinnacle series implantable device to lithotripsy shock waves can cause damage to the device. If the implant site is outside of the shock-wave path, no clear contraindication to the use of lithotripsy can be established. As a precaution, if the patient is not pacemaker dependent, programming the device to OVO/ OAO Mode reduces the possibility of adverse effects. The patient's peripheral pulse should be monitored throughout the treatment, and the implanted Pinnacle series device should be checked for proper operation immediately following the procedure. In an unlikely event, that an operational abnormality is detected, lead repositioning (or replacement) and /or device reprogramming (or replacement) may be indicated.

THERAPEUTIC ULTRASOUND

Direct exposure of a Pinnacle series implantable device to diagnostic ultrasound can cause damage to the device. Moreover, the device may inadvertently concentrate the ultrasonic field and cause harm to the patient.

If the implant site is distant and clearly outside of the ultrasonic field, therapeutic ultrasound may be used. As a precaution, if the patient is not pacemaker dependent, programming the device to OVO/ OAO Mode reduces the possibility of adverse effects.

The patient's and implanted PINNACLE series device should be checked for proper operation immediately following the procedure.

TRANSCUTANEOUS ELECTRICAL NERVE STIMULATORS

Transcutaneous Electrical Nerve Stimulators (TENS) therapy is generally contraindicated for patients implanted with active medical devices. The high-voltage pulses delivered by TENS units to the body can interfere with the operation of the Pinnacle series implantable device.

If a TENS device must be used, the TENS electrodes should be placed as far from the implanted Pinnacle series device and its lead system as possible. The TENS electrodes should also be placed as close as possible to each other to reduce current spread. The operation of the implanted device should be monitored closely during TENS use.

Reprogramming (or replacement), may be indicated.

As a precaution, if the patient is not pacemaker dependent programming the device to OVO/OAO Mode reduces the possibility of adverse effects.

HOME APPLIANCES

Home and commercial microwave ovens in good condition and used as intended, will not affect the implanted Pinnacle series device. Even a severely defective oven that exposes the implantable device to direct microwave energy will not damage the unit itself, although there is the possibility of interference with sensing functions, with repercussions to pacing delivery.

Patients implanted with a Pinnacle series device should be advised about the possibility of interference from some electric razors, electric power tools and electrical ignition systems, including those used on gasoline-powered devices. In general, gasoline-powered devices may be operated by patients implanted with a Pinnacle series device, provided that protective hoods, shrouds and other shielding are not removed.

Certain types of antitheft devices such as those used at entrances/ exits of stores, libraries and other establishments can interfere with the implanted Pinnacle series device. Most commonly, interference would result in asynchronous pacing or pacing inhibition. Patients should be instructed to walk at a normal pace and avoid lingering when passing through the entrances/ exits of these establishments.

INDUSTRIAL MACHINERY

High voltage power lines, electric arc welders, electric smelting furnaces and power generating equipment can interfere with the operation of an implanted Pinnacle series device. For this reason, fields encountered by the patient as a result of his/ her occupation and lifestyle should be considered. When appropriate, specific warnings should be given, or the implanted Pinnacle series device should be programmed so as to minimize susceptibility.

RADIO TRANSMITTERS

Communications equipment such as radio and TV transmitters (including amateur "ham" transmitters, microwave transmitters, and CB transmitters with high-power linear amplifiers) and radar transmitters can interfere with the operation of the implanted Pinnacle series device. For this reason, the intensities and modulation characteristics of the electromagnetic fields encountered by the patient as a result of his/ her occupation and lifestyle should be considered. When appropriate, specific warnings should be given, of the implanted Pinnacle series device should be programmed so as to minimize susceptibility. In general, avoid direct contact and maintain as much distance as possible from electromagnetic field sources.

CELLULAR PHONES

Cellular and other portable telephones can interfere with the operation of the implanted Pinnacle series device. Potential effects may be due to either the radio frequency emitted by these telephones or the magnet within the phone's speaker, and could include asynchronic pacing or pacing inhibition when the phone is in close proximity (within 25cm) of the implanted Pinnacle series device and its lead system. Because of the great variety of cellular phones and the wide variance in patient physiology, an absolute recommendation to cover all patients cannot be made.

A general guideline for patients implanted with a Pinnacle series device who may desire to operate a cellular phone is to hold the phone to the ear opposite the side of the implanted device. Patients should not carry the phone in a breast pocket or on a belt over or within 25cm of the implanted device as some phones emit signals when they are turned on but not in use. Storing the phone in a location opposite the side to the implant is recommended.

Portable (handbag) and mobile (permanent car installation) phones generally transmit at higher power levels compared to hand-held models. For higher-power phones, a minimum, separation of 50cm between the antenna and the implanted device is recommended.

20

POTEINTIAL ADVERSE EFFECTS

Possible side effects may give rise to body rejection phenomena including local tissue reaction, muscle and nerve stimulation, infection and embolism, as well as erosion of the implanted device lead through skin, transvenous lead-related thrombosis, and cardiac tamponade.

21

SIDE EFFECTS









Some side effects can be: local reaction, muscular and nervous stimulation, infection, pacemaker or electrode expulsion due to skin alterations, venous thrombosis due to the leads, and cardiac obstruction



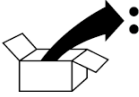

In such cases patient needs an immediate assistance of physician.

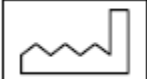
22

SYMBOLS

Explanation of Symbols

Sr. No	Symbol	Symbol Explanation
1.		Operating instructions
2.		Type CF applied part.
3.		Do not dispose of this product in the unsorted municipal waste stream. Dispose of this product according to local regulations
4.		Package contents
5.		Product documentation
6.		Temperature limitation
7.		Serial number
8.		Manufacturer
9.		Date of manufacture
10.		General warning sign
11.		Do Not Reuse

12.		Use By (or Use Before)
13.		Batch Code
14.		Sterile
15.		Sterilized Using ETHYLENE OXIDE
16.		Authorized Representative in the EUROPEAN COMMUNITY"

23 TABLES

Table 01: Physical Characteristics

Table 02: Pacemaker Parameters

Table 02A: Added Parameters

Table 03: Features & Diagnostics Parameters

Table 04: Battery & Pacemaker Life

Table 05: Shipping, Nominal & Emergency Parameters

Table 06: Lead and Connector Compatibility

24 FIGURES

Figure 1: Peeling of pacemaker tray

Figure 2A: PSA to Cable connection

Figure 2B: Lead to Cable connection

Figure 3: Lead's suture sleeve tightens to vein

Figure 4: Lead cavity

Figure 5: Wrench in the Setscrew

Figure 6: Inserting a lead into the device

Warranty

Limited Warranty and Replacement Agreement

SHREE PACETRONIX LTD. (PACETRONIX) provides assurance to the patient that if the Pulse Generator should fail to function within its specified tolerances at any time, due to faulty workmanship or defective components excluding the battery, a functionally equivalent replacement generator shall be delivered to the original implantee, free of charge.

PACETRONIX assures that the generator failed to function within specified tolerances due to battery depletion within five (5) years of the implant date, a functionally equivalent replacement generator shall be furnished to the original implantee, completely free of charge. Characteristics battery depletion is inevitable and therefore not considered to be defect of the generator.

No warranty of replacement agreement whatsoever is made or given as to leads or adapters by this agreement.

Conditions to grant of a replacement

A replacement generator will be granted if and only if (a) the generator to be replaced : (i) was implanted before the USE BEFORE date mark on the generator package in conjunction with a specified lead or a comparable equivalent. (ii) is returned to PACETRONIX (iii) is replaced by a PACETRONIX generator and (b) there is no evidence of improper handling, improper implantation or material alteration of the generator.

Warning

Pinnacle series pacemaker, have a calculated longevity of more than eight (8) years, but due to the hostile environment of the human body, and inspite of the exercise of care in design and manufacturing, the generator may fail by causes beyond the control of PACETRONIX. Care has been taken to prevent such failures, an extensive testing and design effort have preceded the introduction of this product into human clinical use. Although high standards have been used in the production of the device, no representation or warranty can be made that failure or cessation of function will not occur, that adverse body reactions will not arise, or that medical complications will not follow the implantation of the generator.

Limitation of Liability

PACETRONIX shall not be liable for any medical expenses, adverse body reactions, or medical complications or other direct or consequential damages resulting from the implant, removal or replacement of any generator pursuant to this agreement or caused by any defect, failure or malfunction of any generator, lead or adapter, whether such claims for damages is based upon warranty, negligence, contract, strict liability, tort or otherwise. Pacetronix shall issue a free replacement warranty card which will comprise of conditions for allotment of free replacement of generator.

Disclaimer

This limited life time warranty is in lieu of all other warranties expressed or implied. PACETRONIX specifically disclaims any implied warranty of merchantability or fitness for a particular purpose. The remedies set forth herein shall be the exclusive remedies available arising out of the sale or use of the pacer. No person has any authority to bind PACETRONIX to any representation or warranty except as set forth herein.

26

TECHNICAL SERVICE

Members of the technical services department are available to provide technical consultation 24 hours every day for any questions about the pacing system:

In India: Tel. +91 7292 411105,

Fax +91 7292 400418

Address : Plot No. 15, Sector II, Industrial area,

Pithampur 454775, Dist.: Dhar, Madhya Pradesh

Your local sales representative can also provide assistance.

27

GLOSSARY

Anesthetic	A substance that produces numbness or sleep
Arrhythmia	An abnormal rhythm of the heart.
Atrioventricular (AV) Node	The small mass of special tissue that delays the energy pulse traveling from the SA Node to the lower chambers (ventricles) of the heart.
Atrium	One of the two upper chambers of the heart, the right atrium and the left atrium. These chambers receive blood from the body and pump it to the ventricles, the lower chambers of the heart. (Plural = <i>Atria</i>)
Atrial	Relating to the atrium
Bradycardia	An abnormally slow heart rate.
Chamber	One of the four areas in the heart that fill with blood before contracting during the heartbeat. The four chambers are: right atrium, left atrium, right ventricle, and left ventricle.
Congestive Heart Failure	The failure of the heart to pump enough blood to the rest of body, resulting in congestion of blood in the lungs and tissues.
Contraction	Heartbeat, A squeezing of the heart muscle that forces blood out of the heart.

Defibrillation	The use of electric shock to correct rapid heartbeats, usually tachycardia or fibrillation. Defibrillators can be paddles on the outside of the chest or small internal electrodes placed directly on the heart.
Dual-Chamber Pulse Generator	A pulse generator with two leads usually connected to the right atrium and right ventricle.
Electrocardiogram	Often called an EKG or ECG, it is a recording of the electrical activity of the heart.
Electromagnetic Interference	Also known as EMI, this is magnetic or electrical interference from machines or devices which can interrupt the normal operation of a pulse generator.
Electro physiologist	A doctor who specializes in diseases of the electrical system of the heart.
EMI	See “Electromagnetic Interference.”
Fibrillation	An arrhythmia in which the heart quivers rapidly. Atrial fibrillation occurs in the atrium and is usually not life threatening. Ventricular fibrillation occurs in the ventricles and can be fatal.
General Anesthetic	A medication or group of medications that will make the patient unconscious during surgery.
Intravenous (IV)	Inside a vein.
Lead	A special wire connected to the pulse generator and placed inside the heart.
Local Anesthetic	A medication used in surgery that numbs only one area of the body while the patient stays awake.
Node	A cluster or a place where things join, for example, the Sinoatrial Node is where many nerves join.
Pacemaker	Another term for <i>pulse generator</i> or <i>Implantable cardiac device</i> .
Programmer	A special computer designed to communicate with or “program” an implanted pulse generator.
Pulmonary Artery	A blood vessel that carries blood from the right ventricle to the lungs.
Pulmonary Vein	A blood vessel that carries blood from the lungs to the left atrium.

Pulse	A short burst of electricity.
Pulse Generator	A sealed device containing electronic circuitry and a battery, that is designed to send out electrical pulses and correct problems with the heart's rhythm.
Rate-Modulated	A pulse generator that can sense a person's activity and change the heart rate accordingly.
Remote Monitoring	Using a device or machine to transmit information about your pulse generator over a phone line.
Rhythm	The regular beating of your heart.

Single-Chamber Pulse Generator	A pulse generator attached to a single lead.
Sinoatrial (SA) Node	The small mass of special tissue that generates a heartbeat. It is located in the upper right chamber of the heart.
Stimulation Device	Another term for <i>pulse generator</i> .
Tachycardia	An abnormally fast heart rate.
Ventricle	The two lower chambers of the heart. These chambers pump the blood out of the heart into the body.
Ventricular	Relating to the ventricle.